

# International Dart Association

The Official International Dart 18 Class Organisation



## CONTENTS

The Constitution and the Class Rules of the  
International Dart18 Catamaran.

## CONSTITUTION OF THE INTERNATIONAL DART ASSOCIATION

### **1. TITLE - ASSOCIATION**

The full title of the association shall be "THE INTERNATIONAL DART ASSOCIATION"

### **2. OBJECTS**

The objects of the International Dart Association (IDA) are to promote and develop the interests of Dart catamaran owners and sailors throughout the World:-

- (a) to encourage and foster the enjoyment and fellowship of recreational catamaran sailing,
- (b) to encourage and co-ordinate national and international events in the class,
- (c) to co-ordinate and manage the affairs of the class, and
- (d) to maintain the class rules and production one-design character of the Dart catamaran.

### **3. HEADQUARTERS**

The headquarters of the Association shall be in England and the official language shall be English.

### **4. JURISDICTION AND ORGANISATION**

The IDA has authority over all activities of the Dart Catamaran Class throughout the World and its powers shall be vested in and carried out by the International Committee, the International Dart Rules Committee and National or Regional Committees as provided in this Constitution.

### **5. INTERNATIONAL COMMITTEE**

- (a) The Association shall be governed by the International Committee comprising of the chairman of each National or Regional Committee from time to time holding office, the immediate Past Chairman of the International Committee, and such additional officers to be appointed by the Committee for such term as it may from time to time determine.
- (b) The International Committee shall meet from time to time at the request of the Chairman or three other members.
- (c) The International Committee shall elect from amongst themselves the Chairman and Vice Chairman of the Association, who shall hold office until their successors are elected to office.
- (d) In the event that a National or Regional Chairman is unable to attend any meeting of the International Committee, the Secretary or any other member of the National or Regional Committee nominated for that purpose may attend and represent the Chairman and vote at such meeting of the International Committee.
- (e) In the absence of the Chairman of the International Committee the Vice Chairman shall act as Chairman and not the Vice Chairman's alternate. In the absence of both the Chairman and the Vice Chairman the meeting shall be adjourned to a later date.
- (f) The quorum shall be half the number of National or Regional Associations then in being rounded up to the nearest whole number.
- (g) Each Committee member shall have one vote. Decisions shall be reached by a simple majority, and in the event of an equality of votes the Chairman of the meeting shall have an additional vote.
- (h) A representative nominated by Bryher Mouldings Ltd., shall have the right to attend and speak at all International Committee Meeting but shall have no voting rights unless elected as a Committee member.
- (i) Twenty-one days notice of International Committee Meetings must be given to all Committee Members, including the nominated Bryher Moulders Ltd. Representative. The notice of the meeting shall include an agenda.
- (j) A Secretary (non-voting) shall be appointed by the International Committee upon such terms as the International Committee may think fit
- (k) The Secretary shall be responsible, under the supervision of the Chairman, for the maintenance of the affairs of the Association including the following:

*Minutes of the International Committee*

*Minutes of the Advisory Council*

*Register of Members*

*Register of Boats*

- (l) The International Committee shall cause proper books of account to be kept of all income and expenditure and of all dealings with the assets of the Association and shall circulate annually to all members a duly audited income and expenditure account and balance sheet.
- (m) The International Committee shall refer all matters concerning the Dart Class Rules, including interpretations, to the International Dart Rules Committee (IDRC) for their decision.
- (n) The IDRC shall appoint, on such terms as it may think fit, a Chief Inspector (non-voting).

## **6. INTERNATIONAL DART RULES COMMITTEE**

- (a) The IDRC shall assist and co-operate with the International Committee in the carrying out of their responsibilities and shall have the duties and power provided by the Constitution.
- (b) The IRDC shall consist of the following three members:-
  - Current Chairman of the IDA International Committee*
  - A representatives nominated by Bryher Mouldings, Ltd.*
  - A third person familiar with the Dart18 and acceptable to the other two members.*
- (c) The three members shall form a quorum.
- (d) The IRDC shall have the absolute right to veto or approve amendments to whether the Association Constitute or the Dart Class Rules.
- (e) Each member shall have one vote. Decisions shall be reached by a simple majority except on matters concerning the IDA Constitution or Dart Class Rules. Approval for amendments to either the IDA Constitution to Dart Class Rules must be carried by a unanimous vote and conveyed to the International Committee in writing against the signatures of all three members of the IDRC.

## **7. NATIONAL OR REGIONAL COMMITTEES**

The International Committee may, as and when it deems it necessary for the administration of the affairs of the Association, form National or Regional Associations.

- (a) The International Committee shall have power to approve, amalgamate or disband National or Regional Associations. In special circumstances the International Committee may approve separate regional Associations within one country.
- (b) Each national or Regional Association shall elect annually a National or Regional Committee which shall consist of the following who must all be full or associate members of the Association:-
  - Chairman*
  - Secretary*
  - Treasurer*
  - Not less than two others*
- (c) Each National or Regional Committee shall manage within it's area those affairs of the Association which may be delegated to it by the International Committee.
- (d) The National or Regional Committee shall be elected annually at the National or Regional Annual General Meeting (AGM) and each Committee member shall serve until the conclusion of the following National or Regional AGM
- (e) Four members shall form a quorum
- (f) Each Committee member shall have one vote. Decisions shall be reached by a simple majority and, in the event of an equality of votes, the Chairman of the meeting shall have an additional vote.
- (g) In the event of vacancies occurring on the Committee for any reason whatsoever, the Committee shall have the power to co-opt replacements.
- (h) Fourteen days notice of Committee meetings must be given to all Committee members. The notice of the meeting shall include an agenda.

## **8. NATIONAL OR REGIONAL ANNUAL GENERAL MEETINGS**

- (a) The AGM of each National or Regional Association shall be held at a time and place of their choosing.
- (b) Business at the AGM shall comprise:-
  - (i) Chairman's report
  - (ii) Secretary's report
  - (iii) Treasurer's report and presentation of accounts
  - (iv) Election of officers and committee
  - (v) Election of Honorary auditors
  - (vi) Proposals, of which notice has been received 4 weeks prior to the date chosen in 8(a), by the Secretary, who should in turn advise all Members of these proposals 21 days before the AGM
- (c) Extraordinary General Meetings may be called by the Association Committee, or shall be called by the Chairman upon receipt by the Secretary of a request in writing,. Signed by not fewer than ten members of the Association.
- (d) At least 21 days notice, together with a copy of the agenda, shall be given to all Members of any General Meeting.
- (e) At any General Meeting decisions shall be made by a simple majority.
- (f) Voting to be by show of hands unless a poll is demanded by not fewer than three of the members present. At General Meetings both full and associate members may be allowed to join in discussion but only full; members may vote. In the event of an equality of votes, the Chairman shall have an additional vote.

## **9. FLEETS**

- (a) Fleets may be formed by Association Members in any locality upon application to the National or Regional Committee or the International Committee where the locality is not within a National or Regional Association.
- (b) The National or Regional Committee or, if appropriate, the International Committee, shall have the power to approve, amalgamate or disband fleets.
- (c) A Fleet Captain, and such other officers as the Fleet may deem necessary, shall be elected annually from among the members or the Fleet in such manner as is prescribed by the Fleet unless otherwise provided by the Constitution. The Fleet Captain and any other Fleet Officers shall be responsible to the National or Regional Committee (or, if appropriate, the International Committee) for the affairs and conduct of the Fleet and due compliance by the Members with the IDA.

## **10. NOTICE OF MEETINGS AND POSTAL VOTES**

- (a) Notice of meetings or ballot papers shall be deemed to be served if posted by email to the last known address of the Member.
- (b) Non-receipt of notices or ballot papers by Members, or of postal votes by the auditors, shall not invalidate the proceedings of meetings or the result of a postal ballot.

## **11. MEMBERSHIP**

- (a) Full Membership shall, upon payment of the prescribed annual subscription, be open to any owner of a Dart, or in the case of joint owners, to not more than one of them, or in case of a Dart owned by a Corporation or Association, to a nominated representative of that organisation.
- (b) Associate Memberships shall, upon payment of the prescribed annual subscription, be open to any person or club interested in the Dart Class.
- (c) Honorary Memberships. The International Committee may grant honorary life membership to any persons as a mark of respect or appreciation of exception service to the Association. An honorary life member who would otherwise qualify for full membership under Rule4(a) shall be entitled to all privileges and voting rights of such membership without payment of annual subscriptions.
- (d) A member of the Association "ipso facto" belongs to the National or Regional Association in which he normally sails, even though such place may not be his permanent residence; but such member, for valid reason and with the approval of both National or Regional Chairman, may select instead the National or Regional Association in which he has his permanent residence.

## **12. SUBSCRIPTIONS**

- (a) Association subscriptions shall be the amounts determined by and shall be payable within the time prescribed by By-Law of each National or Regional Association, as determined by the International Committee, and shall include all amounts required for International Committee, National or Regional purposes as determined by each authority.
- (b) The Association may ask for special contributions in addition to subscriptions, provided any such contribution shall be for a specific purpose and shall not be mandatory.

## **13. SUSPENSION OF MEMBERSHIP**

A member may be suspended by the International Committee, on the recommendation of a National or Regional Association, for gross violation of the rules or By-laws, for committing an unlawful act in relation to the Association or one of its members, or for any unsporting conduct contrary to the interests of the members of the Association. The duration of the suspension shall be fixed by the International Committee but may not exceed two years and a suspended member shall during such period be precluded from racing or enjoying any other rights of Membership.

## **REMOVAL FROM OFFICE**

A National or Regional Officer may be removed from office by the International Committee for a wilful and unjustifiable act of commission or omission detrimental to the Association or to its members.

## **15. APPEALS**

- (a) Any dispute arising in relation to fleets, Championship Rules, regions, eligibility to race, the By-laws or similar matter, other than any dispute as to the interpretation of this Constitution and the Class Rules, may be made to the International Committee, whose decision shall be final and binding.
- (b) Any dispute as to the interpretation of this Constitution and the Class Rules may be made to the IDRC whose decision shall be final and binding.

#### **16. AMENDMENTS TO THE CLASS RULES**

The Class Rules shall only be amended by the IDRC. Proposals for changes in the Class Rules may be submitted to the IDRC by the International Committee provided that at least two-thirds of the National or Regional Associations have approved such proposed amendment at Special General Meetings of their Association called for that purpose, or at the Annual General Meeting of their Associations provided not less than twenty-one days notice of such proposed amendments has in each case been given.

#### **17. AMENDMENTS TO THE CONSTITUTION**

- (a) This Constitution may be amended by the International Committee, with the approval of the IDRC, provided that at least two-thirds of the National or Regional Associations have approved a proposed amendment at Special General Meetings of their Association called for that purpose, or at the Annual General Meetings of their Association provided not less than twenty-one days notice of a proposed amendment has in each case been given.
- (b) Amendments to the Constitution shall be submitted for vote of National of Regional Association:-
  - (i) by direction of the International Committee; or
  - (ii) by direction of the International Secretary where notice of motion, signed by at least twenty members, has been submitted to and approved by at least two National and Regional Associations.

#### **18. INTERIM CONSTITUTION**

- (a) Until such time as there are five or more National or Regional Associations, the International Committee shall consist of the nominated members of the IDRC and the Chairman of the National or Regional Committees then in being.
- (b) Three members of the International Committee shall form a quorum.

## INTERNATIONAL DART18 CLASS RULES

### **1. GENERAL**

- (a) The official language of the Class is English and in the event of dispute over interpretation the English text shall prevail.
- (b) These rules and drawings referred to herein shall take precedence.
- (c) The International Dart18 Association accepts no legal responsibility in respect of these rules or any claim arising there from.
- (d) Where there is no 'National Owners' Association, or the National Association does not wish to administer the Class, its function as stated in these rules shall be carried out by the IDA or its delegated representative.
- (e) These rules shall be administered by the International Dart18 Rules Committee (IDRC).

### **2. BUILDERS**

- (a) Builders of the Dart18 shall be only those licensed by Bryher Mouldings, Ltd.
- (b) Sail-makers shall be only those licensed by Bryher Mouldings, Ltd.

### **3. REGISTRATION**

- (a) Measurement Certificates for boats are no longer required (March 2010).
- (b) Boats sold by Bryher Licensees shall comply with the Class Rules and be accompanied by an up to date set of these Rules. Bryher Mouldings Ltd. shall maintain a record of hull and sail numbers of new boats sold by their licensees.
- (c) Owners attending Regattas must make sure their boat complies with these Rules and make their boats available for scrutiny by the organisers.
- (d) Second hand boats whose hulls may have been replaced or the sail number is missing shall apply to Bryher Mouldings Ltd. for a replacement sail number. That four figure number will start with a zero.

### **4. RECOGNITION MARKS**

- (a) The hull production number shall be indelibly marked in the laminate such that it can be read through the rear hatch opening, on the transom or at the inside rear of the hulls.
- (b) The sail numbers and Class emblems shall be placed on both sides of the mainsail, as shown on Drawing No. 020. Sail numbers and emblems shall sharply contrast in colour with the sail and shall be placed at different heights on the two sides of the sail, those on the starboard side being uppermost. Class emblems, letters and numbers on the sail shall be of the size down on Drawing Nos. DS423 and DS424 respectively.
- (c) Sail-maker's marks shall be placed near the tack of the sails and shall not exceed 150mm by 150mm.

### **5. SPECIFICATION**

- (a) The specification of the Dart18 is contained in the following drawings and documents:-
  - (i) Owners drawings which detail the equipment and fittings which an owner may replace from any source, as stated in Rule 9(b). These drawings are available to all.
  - (ii) One Design Drawings which describe the hull, spars and other equipment supplied by the approved sources, stated in Rule 9(a). These drawings shall be in the custody of the IDRC and are available at the time of any dispute, only to officials approved by the IDRC.
- (b) This is a Production One Design Class. Measurement tolerances are intended to allow for random manufacturing variations only and shall not be deliberately used to alter the design. Any alterations to the hull, construction, equipment, spars, sails or running rigging, as supplied by the manufacturers, except as specifically authorised by these Rules, is prohibited.
- (c) All boats shall comply with the drawings and documents specified in 6(a). Whilst racing, all equipment shown in these drawings shall be carried and assembled as specified, except that listed in 5(c). When one person only is on board, the jib may be left ashore.
- (d) In the case of a measurement dispute not explicitly covered by these Drawings, the following procedures shall be adopted:-

A random sample of 15 boats shall be taken and measured using identical techniques. The dimensions of the disputed boat shall be equal to, or between, the maximum and the minimum dimensions obtained from these 15 boats. If the boat in question is outside these dimensions the matter, together with all relevant information, shall be referred to the IDRC who shall give a final ruling. If any of the dimensions of the sample are considered to be unusual, all relevant information shall be referred to the IDRC.

- (e) Hulls shall be built only by Licensed Builders from official moulds issued by Bryher Mouldings Ltd. All official moulds shall be produced only from the master plugs approved and certified by the IDRC. The IDRC may inspect at any reasonable time all moulds and master plugs. The IDRC shall have power to withdraw from use any moulds or master plugs which, in their opinion, are not of a standard to preserve the strict one-design of the Dart18. The IDRC may delegate such inspection duties to an official inspector.
- (f) Sails shall be manufactured only by Licensed Sail-makers from patterns supplied by Bryher Moulds Ltd., and approved and certified by the IDRC.
- (g) Only an official inspector recognised by the IDRC shall be able to verify the authenticity of a boat. Payment for the inspector's services is the responsibility of the owner.
- (h) An official inspector shall not verify the authenticity of a boat or any part of a boat owned by themselves.
- (i) All certified boats shall be liable to examination at the discretion of the IDRC or Race Committee, but only by a recognised official inspector.
- (j) In the event of any damage to a boat, necessary repairs may be made, subject to Rule 5(a), provided that repairs are made in such a way that the essential shape or other characteristics are not affected. The boat shall be re-examined in respect of the affected parts by an official inspector.
- (k) Any dispute regarding the measurement of a boat or the interpretation of these Rules shall be referred to the IDRC for ruling. Any ruling shall require a unanimous decision which shall be final and binding.

**6. MISCELLANEOUS**

- (a) The trapeze gear shall be used by only one person at a time who shall have at least one foot in contact with the boat.
- (b) Both rudders shall be at all times in the fully down position except when clearing underwater obstructions.
- (c) No person may re-cut any sail or otherwise change or affect any aspect of the sail for any reason other than necessary repairs or placing racing numbers thereon.
- (d) Hulls and rudder blades which require refinishing may be painted.
- (e) Split rings, split pins and mast spanner anchoring may be protected from casual snagging but not to reduce windage.

**7. SAFETY**

- (a) The following equipment shall be carried on board while racing:
- (b) A paddle, to conform to Drawing No DA440
- (c) Personal buoyancy for each crew member.

**8. PERSONS ON BOARD**

- (a) The crew, including helms, shall consist of one or two persons. When one person only is on board, the jib shall not be set or used.
- (a) Replacement hulls, spars and equipment other than that listed under Rule 9(b) shall be supplied only by licensed builders and their agents or suppliers approved by Bryher Mouldings Ltd.
- (b) Only fastenings and equipment whose part numbers are listed in Table 1 may be replaced from any source provided that they comply with the specifications, general appearance and dimensions shown in the accompanying drawings.

The following parts may be removed:-

DA443	DS405
DA445	
DM356	DS412
DM357	DS430
DM372	DS431
DR251 or DR261	DS435
	DT203
	DW313

TABLE 1  
REPLACEMENT PART NUMBERS

Accessories	Beams	Hulls	Mast	Rudders	Sails	Trampoline	Wires & Rigging
DA440	DB 153	DH 110	DM 345	DR 250	DS 380	DT 192	DW 280
DA443	DB 155	DH 111	DM 346	DR 251	DS 381	DT 193	DW 281
DA445	DB 158	DH 112	DM 349	DR 252	DS 382	DT 194	DW 282
	DB 163	DH 114	DM 354	DR 254	DS 383	DT 195	DW 283
	DB 166	DH 115	DM 355	DR 255	DS 384	DT 196	DW 284
	DB 167	DH 116	DM 356	DR 256	DS 385	DT 198	DW 285
	DB 168	DH 117	DM 357	DR 257	DS 386	DT 199	DW 288
	DB 169	DH 118	DM 359	DR 258	DS 390	DT 200	DW 289
	DB 171	DH 119	DM 360	DR 259	DS 400	DT 202	DW 300
	DB 173	DH 120	DM 361	DR 261	DS 401	DT 203	DW 301
	DB 174	DH 121	DM 362	DR 262	DS 402	DT 204	DW 302
	DB 176	DH 122	DM 364	DR 502	DS 404	DT 205	DW 303
	DB 177	DH 123	DM 366	DR600	DS 405	DT 206	DW 310
	DB 178	DH 126	DM 367	DR601	DS 410	DT 207	DW 311
	DB 179	DH 127	DM 368	DR602	DS 412		DW 312
	DB 517	DH 128	DM 370	DR603	DS 419		DW 313
	DB 518	DH 130			DS 423		DW 320
		DH 131			DS 424		DW 321
		DH 132			DS 425		DW 322
		DH 135			DS 430		DW 323
					DS 431		DW 324
					DS 432		DW 329
					DS 433		DW 330
					DS 434		DW 331
					DS 512		DW 332
					DS 514		DW 333
					DS 515		DW 334

10. AMENDMENTS TO THESE RULES by the IDRC

- (a) May 2010
  - (i) Building Fee removed. No longer applicable. (ii) Registration re-written.
- (b) May 2011
  - (i) Alternative tiller bar length adjuster introduced - DR600 to fit DR250.
- (c) August 2013
  - (i) 6)e was added. (ii) DS412 replaceable with DS435. (iii) 9)c was added to. (iv) Alternative mainsail downhaul was added. (v) DM372 was added. (vi) DS 514 and DS 515 were added as replacement parts.
- (d) September 2017
  - (i) DS404 replaced with DS435 and DS436. (ii) DS436 was added. (iii) DW284 overall length modified to 60 +/- 35.
  - (ii) DS401 minimum diameter reduced to 5mm. (v) DT197 replaced with pocket sewn to trampoline.
- (e) January 2020
  - (i) DR600 to DR603 added—rudder lock spring adjuster.

NOTE All previous editions of the Parts shown from this page onwards remain valid and legal.

**See the Class Rules Drawings for Parts replaceable from any source and listed in Table 1**



CLASS RULES DRAWINGS

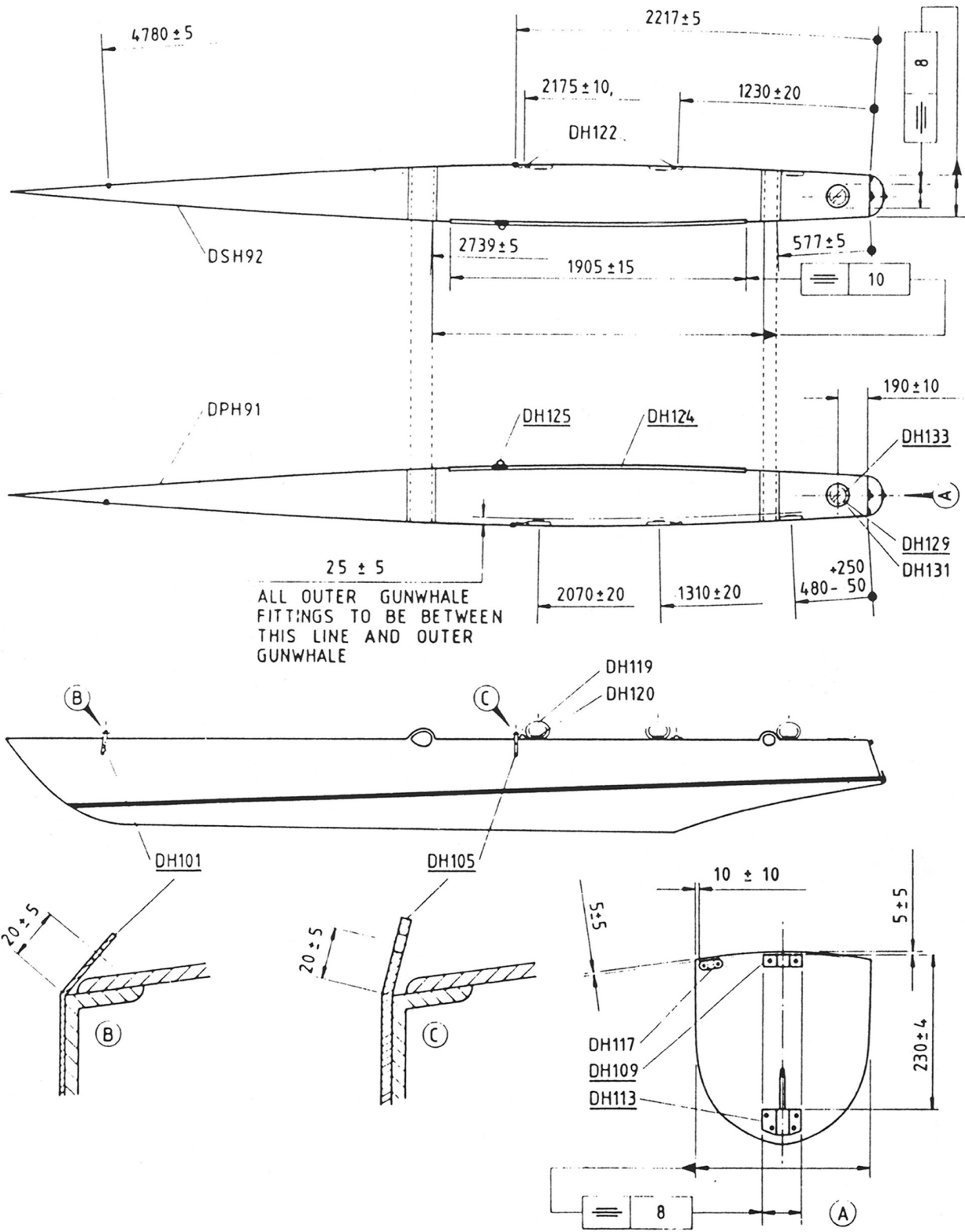

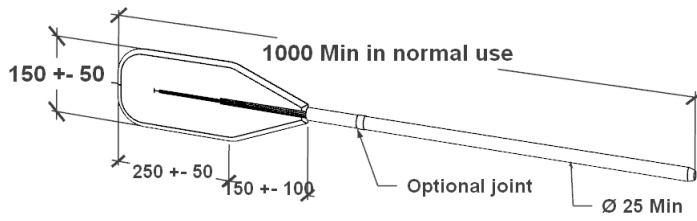

MATERIAL:

Optional—Minimum weight 300 grms

DA440

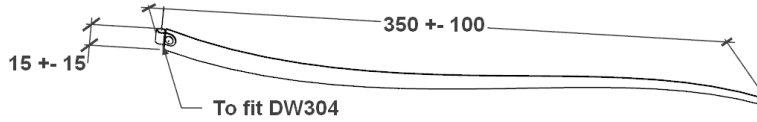

MATERIAL:

FLEXIBLE CLOTH FIBRES

DA443

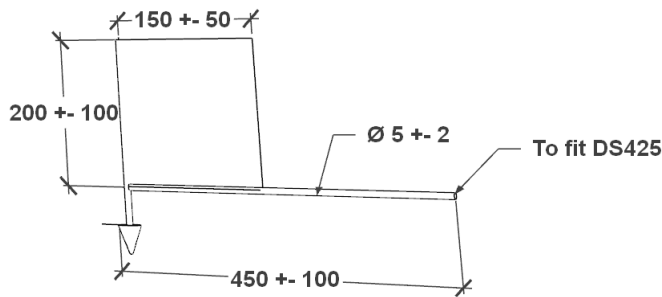

MATERIAL:

OPTIONAL

DA445

MATERIAL:

MATERIAL:

MATERIAL:

MATERIAL:

MATERIAL:

MATERIAL:

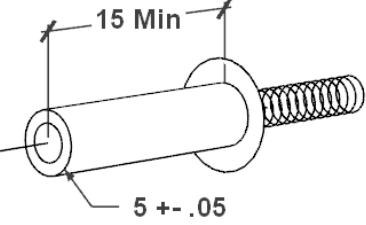
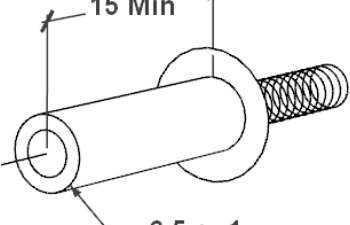
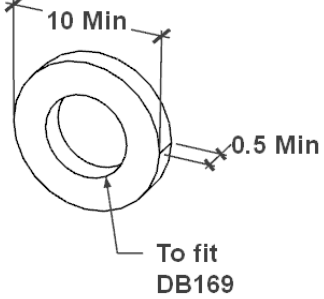
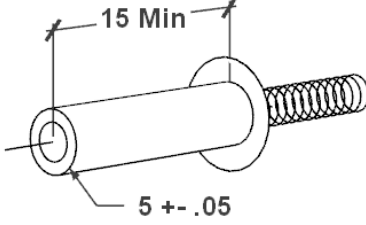
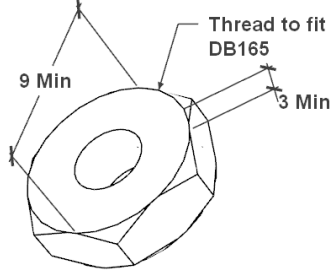
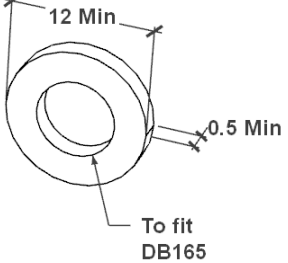
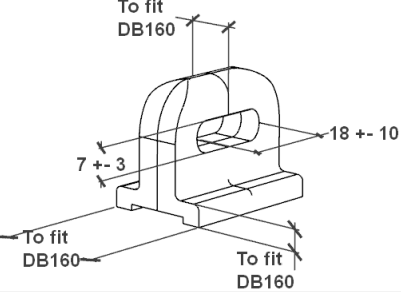
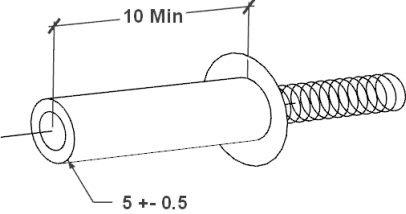
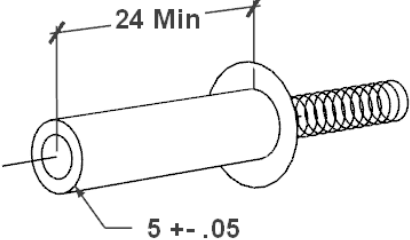
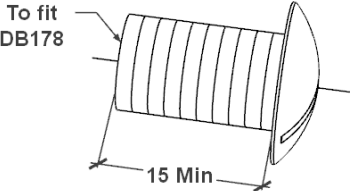
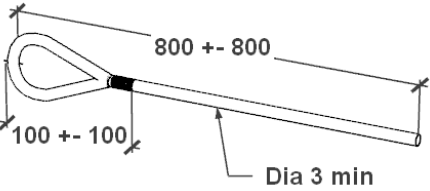
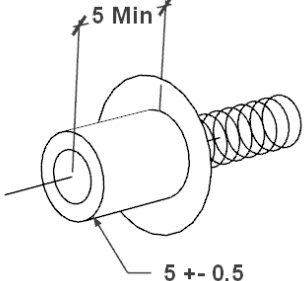
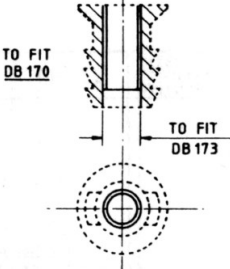
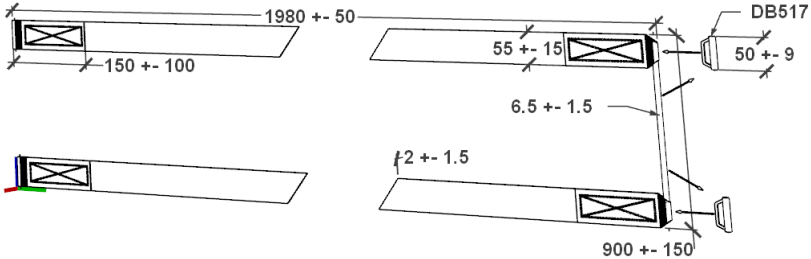
					
<b>MATERIAL:</b> <b>Monel, Stainless steel</b>	<b>DB153</b>	<b>MATERIAL:</b> <b>Monel, Stainless steel</b>	<b>DB155</b>	<b>MATERIAL:</b> <b>Stainless steel</b>	<b>DB158</b>
					
<b>MATERIAL:</b> <b>Monel, Stainless steel</b>	<b>DB163</b>	<b>MATERIAL:</b> <b>Stainless steel</b>	<b>DB166</b>	<b>MATERIAL:</b> <b>Stainless steel</b>	<b>DB167</b>
					
<b>MATERIAL:</b> <b>Plastic synthetic composite</b>	<b>DB168</b>	<b>MATERIAL:</b> <b>Aluminium alloy, Monel, Stainless steel</b>	<b>DB169</b>	<b>MATERIAL:</b> <b>Aluminium alloy, Monel, Stainless steel</b>	<b>DB171</b>
					
<b>MATERIAL:</b> <b>Stainless steel</b>	<b>DB173</b>	<b>MATERIAL:</b> <b>Fibre rope-Toe strap</b>	<b>DB176</b>	<b>MATERIAL:</b> <b>Aluminium alloy, Monel, Stainless steel</b>	<b>DB177</b>
					
<b>MATERIAL:</b> <b>Plastic synthetic composite</b>	<b>DB178</b>	<b>MATERIAL:</b> <b>Optional</b>			<b>DB174/ 517</b>

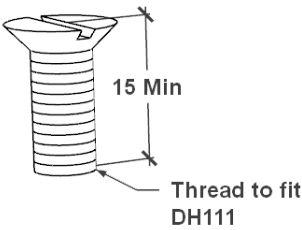
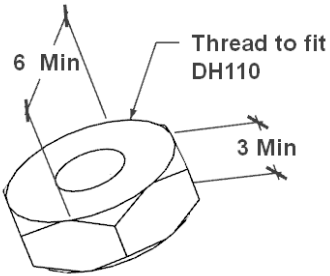
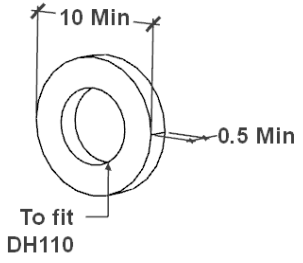
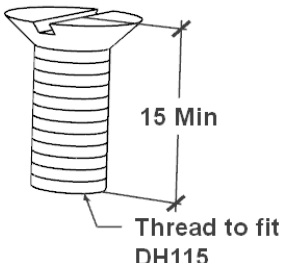
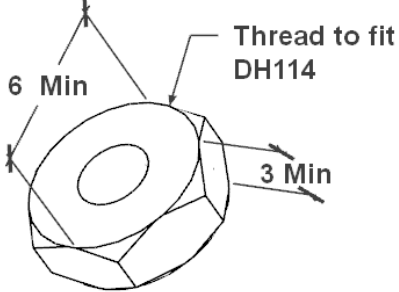
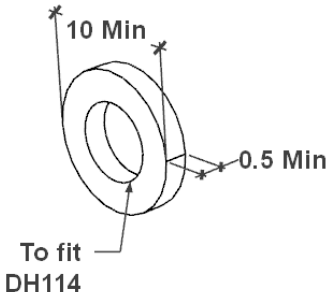
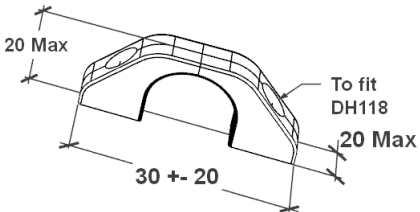
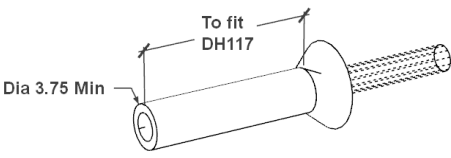
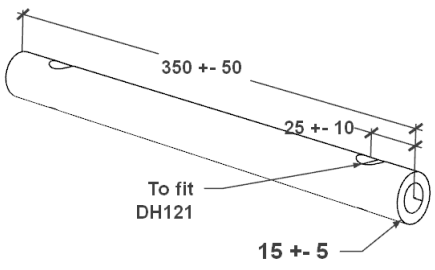
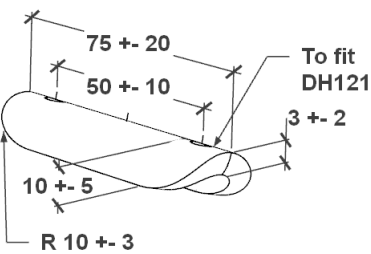
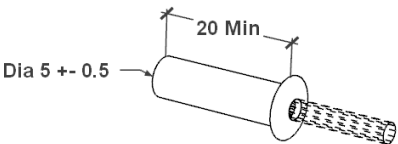
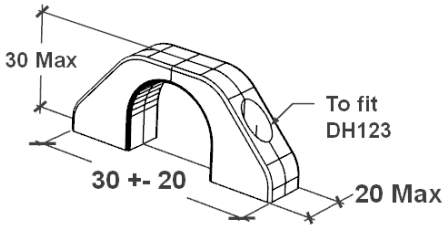
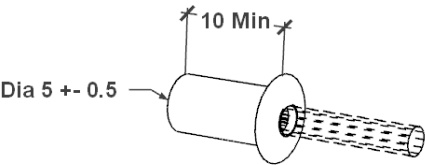
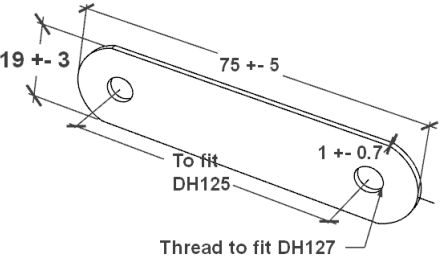
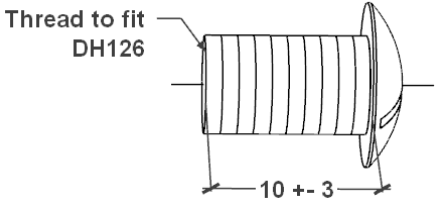
					
MATERIAL:	<b>Stainless steel</b>	<b>DH110</b>	MATERIAL:	<b>Stainless steel</b>	<b>DH111</b>
					
MATERIAL:	<b>Stainless steel</b>	<b>DH114</b>	MATERIAL:	<b>Stainless steel</b>	<b>DH115</b>
					
MATERIAL:	<b>Optional</b>	<b>DH117</b>	MATERIAL:	<b>Aluminium alloy, Monel, Stainless steel</b>	<b>DH118</b>
					
MATERIAL:	<b>Optional</b>	<b>DH119</b>	MATERIAL:	<b>Aluminium alloy, Monel, Stainless steel</b>	<b>DH120</b>
MATERIAL:	<b>Optional</b>	<b>DH122</b>	MATERIAL:	<b>Optional</b>	<b>DH123</b>
					
MATERIAL:	<b>Aluminium alloy, Monel, Stainless steel</b>	<b>DH123</b>	MATERIAL:	<b>Stainless steel</b>	<b>DH126</b>
MATERIAL:	<b>Aluminium alloy, Monel, Stainless steel</b>	<b>DH127</b>	MATERIAL:	<b>Stainless steel</b>	<b>DH127</b>

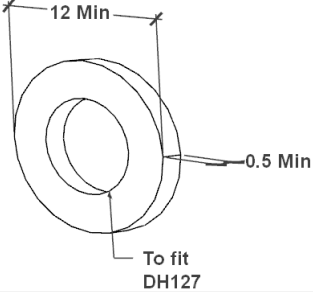
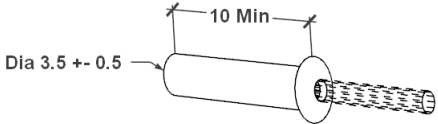
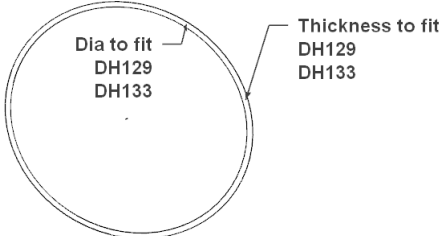
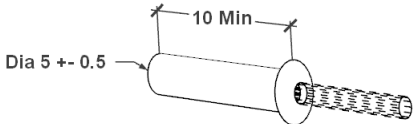
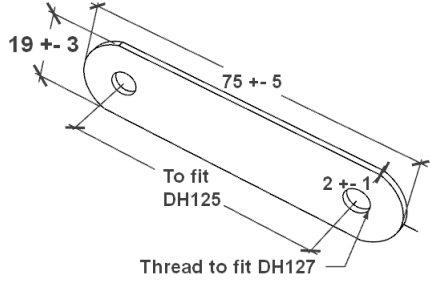
											
<b>MATERIAL:</b> <b>Stainless steel</b>		<b>DH128</b>		<b>MATERIAL:</b> <b>Aluminium alloy, Monel, Stainless steel</b>		<b>DH130</b>		<b>MATERIAL:</b> <b>Flexible</b>		<b>DH131</b>	
											
<b>MATERIAL:</b> <b>Aluminium alloy, Monel, Stainless steel</b>		<b>DH132</b>		<b>MATERIAL:</b> <b>Metal, plastic, plastic composite</b>		<b>DH135</b>		<b>MATERIAL:</b>			
<b>MATERIAL:</b>				<b>MATERIAL:</b>				<b>MATERIAL:</b>			
<b>MATERIAL:</b>				<b>MATERIAL:</b>				<b>MATERIAL:</b>			
<b>MATERIAL:</b>				<b>MATERIAL:</b>				<b>MATERIAL:</b>			

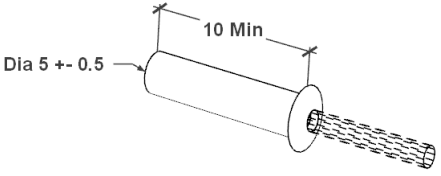
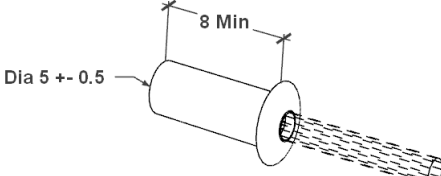
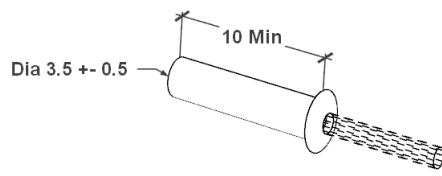
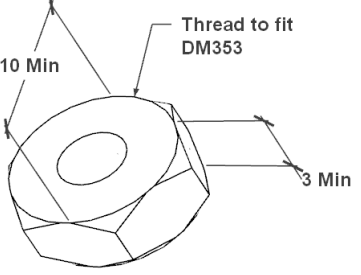
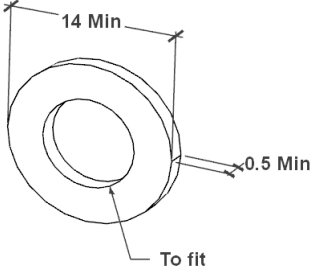
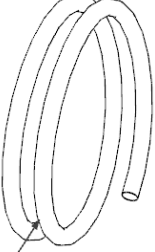
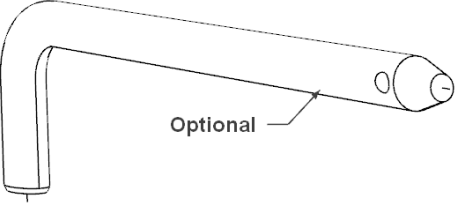
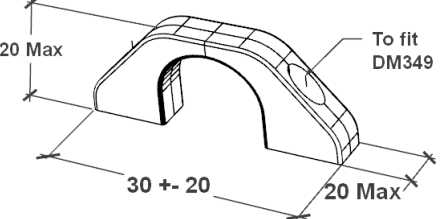
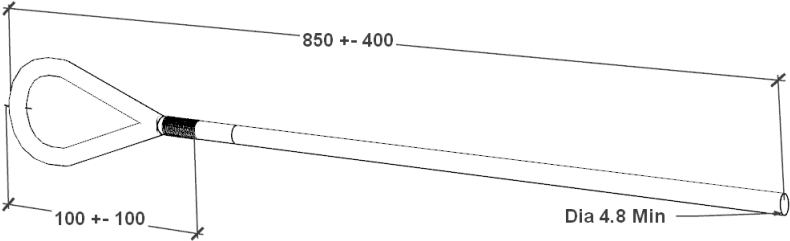
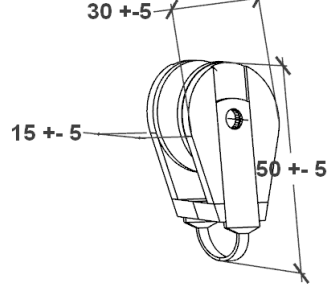
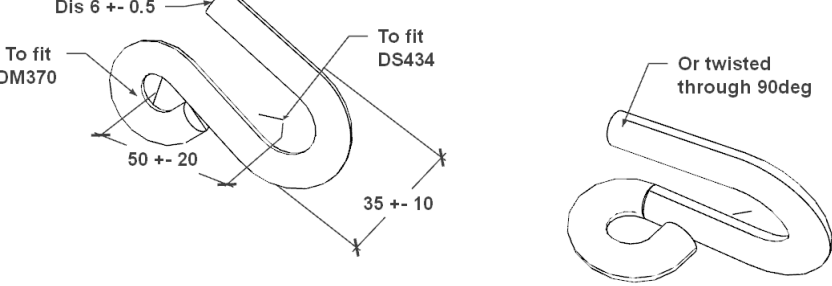
 <p>Dia 5 +/- 0.5 10 Min</p>	 <p>Dia 5 +/- 0.5 8 Min</p>	 <p>Dia 3.5 +/- 0.5 10 Min</p>			
<p>MATERIAL: Aluminium alloy, Monel, Stainless steel</p>	<p><b>DM345</b></p>	<p>MATERIAL: Monel, Stainless steel</p>	<p><b>DM346</b></p>	<p>MATERIAL: Aluminium alloy, Monel, Stainless steel</p>	<p><b>DM349</b></p>
 <p>10 Min Thread to fit DM353 3 Min</p>	 <p>14 Min 0.5 Min To fit DM353</p>	 <p>Optional</p>			
<p>MATERIAL: Stainless steel</p>	<p><b>DM354</b></p>	<p>MATERIAL: Stainless steel</p>	<p><b>DM355</b></p>	<p>MATERIAL: Clevis pin fastener</p>	<p><b>DM357</b></p>
 <p>Optional</p>	 <p>20 Max To fit DM349 30 +/- 20 20 Max</p>				
<p>MATERIAL: Optional</p>	<p><b>DM356</b></p>	<p>MATERIAL: Optional</p>	<p><b>DM359</b></p>		
 <p>850 +/- 400 100 +/- 100 Dia 4.8 Min</p>	 <p>30 +/- 5 15 +/- 5 50 +/- 5</p>				
<p>MATERIAL: Fibre rope-Downhaul</p>	<p><b>DM360</b></p>	<p>MATERIAL: Plastic, stainless steel, plastic composite</p>	<p><b>DM371</b></p>		
 <p>Dis 6 +/- 0.5 To fit DM370 50 +/- 20 35 +/- 10 To fit DS434 Or twisted through 90deg</p>					
<p>MATERIAL: Stainless steel</p>	<p><b>DM361</b></p>	<p>MATERIAL:</p>			

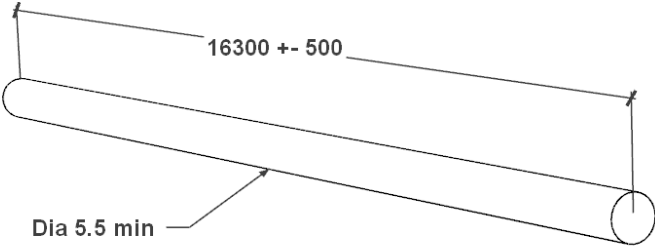
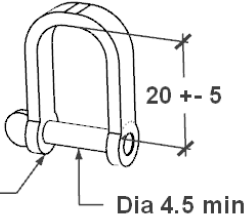
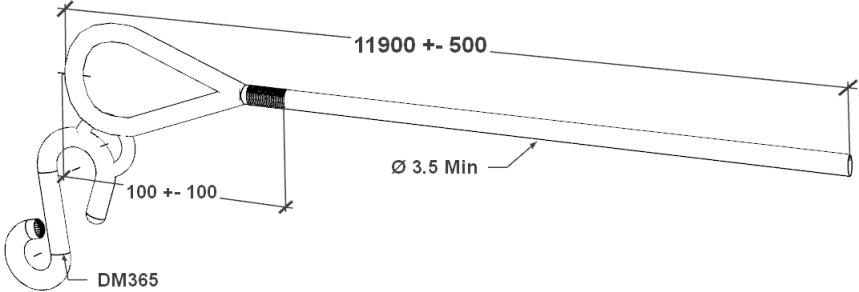
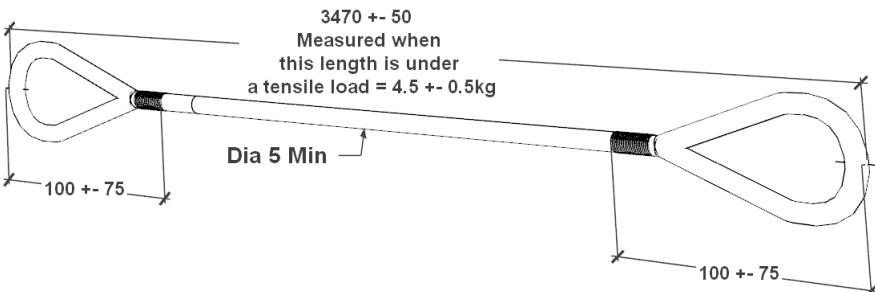
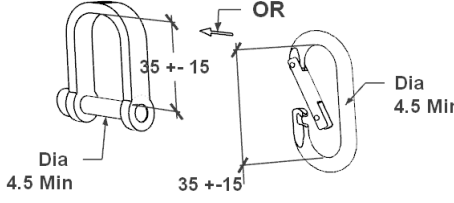
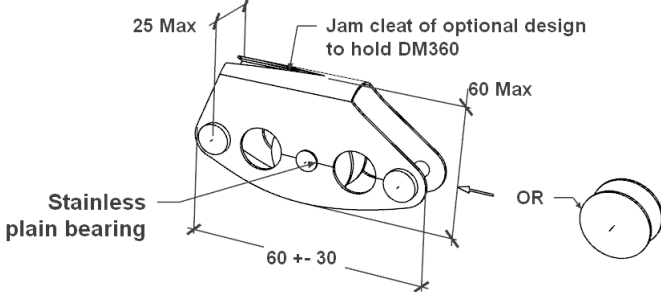
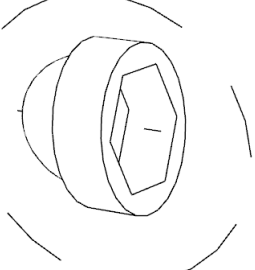
		
<p>MATERIAL: <b>Fibre rope—Main halyard</b></p>	<p><b>DM362</b></p>	<p>MATERIAL: <b>Stainless steel</b></p> <p><b>DM366</b></p>
		
<p>MATERIAL: <b>Fibre rope—Jib halyard</b></p>	<p><b>DM364</b></p>	<p>MATERIAL:</p>
		
<p>MATERIAL: <b>Fibre rope—Spanner line</b></p>	<p><b>DM367</b></p>	<p>MATERIAL: <b>Stainless steel</b></p> <p><b>DM368</b></p>
		
<p>MATERIAL: <b>Optional</b></p>	<p><b>DM370</b></p>	<p>MATERIAL:</p>
<p>MATERIAL:</p>		
<p>MATERIAL:</p>		<p>MATERIAL: <b>Plastic composite</b></p> <p><b>DM374</b></p>

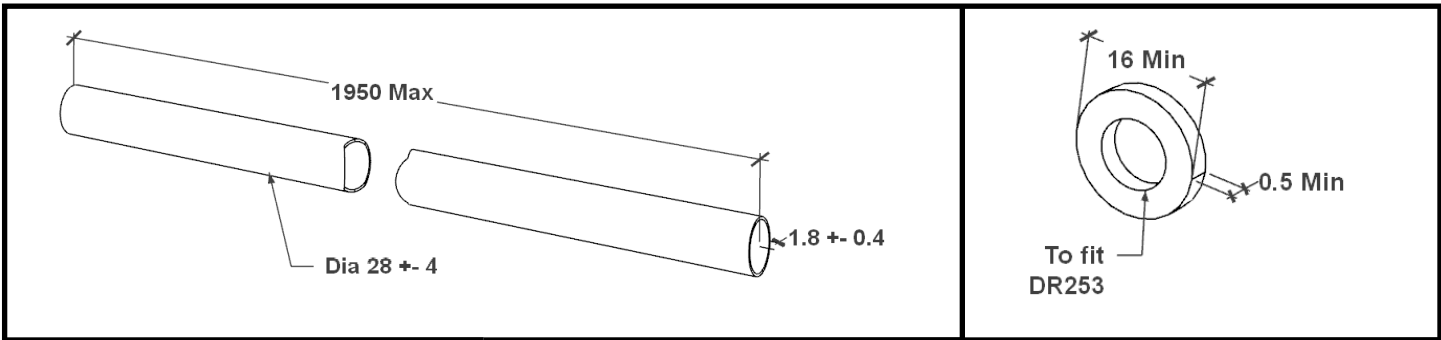

MATERIAL: Aluminium alloy

DR250

MATERIAL: Stainless steel

DR254

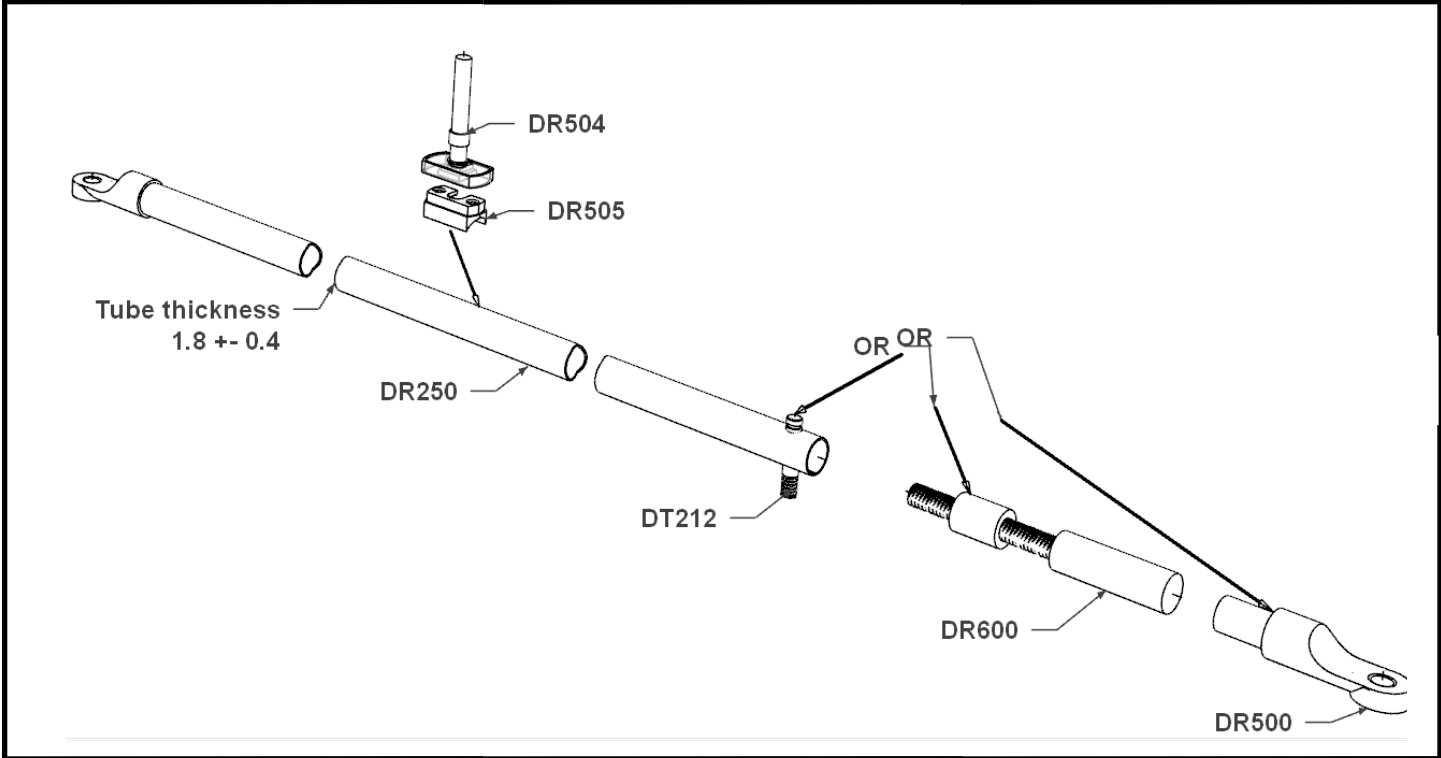

MATERIAL: Plastic, stainless steel, plastic composite

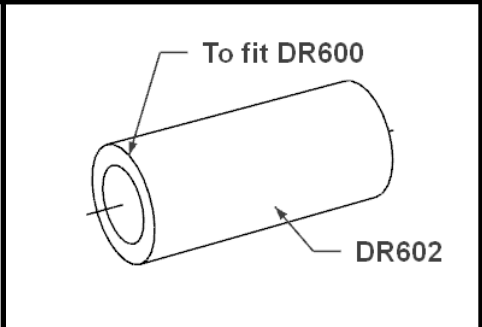
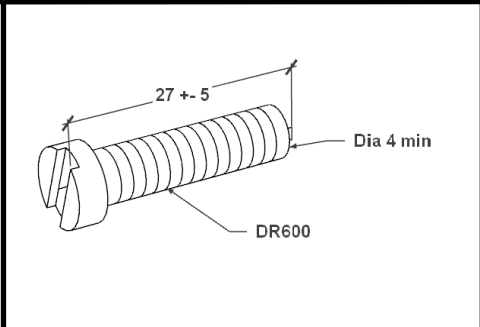
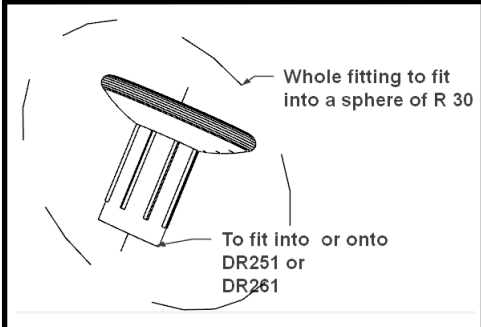

MATERIAL: Plastic composite

DR252

MATERIAL:

MATERIAL:

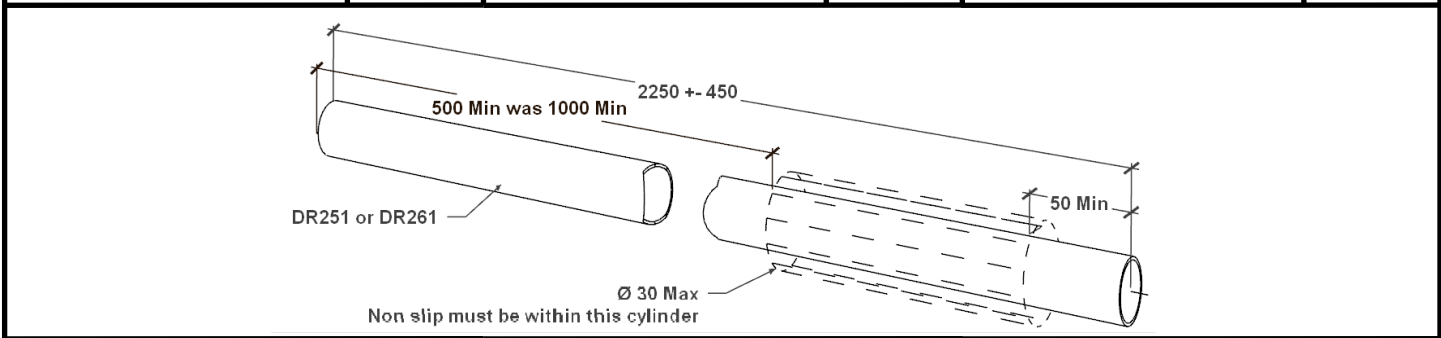

MATERIAL: Aluminium alloy

DR251  
DR261

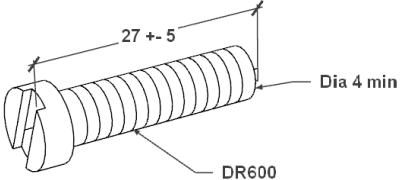
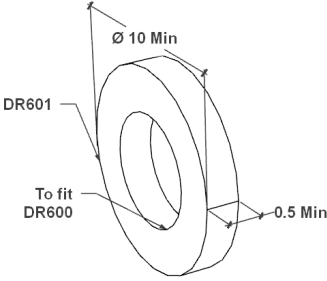
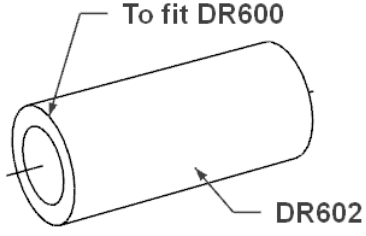
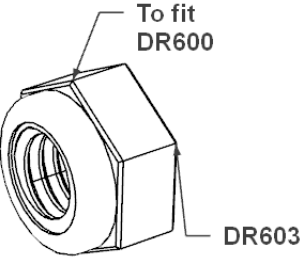

					
MATERIAL: <b>Stainless steel</b>	<b>DR600</b>	MATERIAL: <b>Stainless steel</b>	<b>DR601</b>	MATERI- <b>Flexible tube</b>	<b>DR602</b>
					
MATERIAL: <b>Stainless steel</b>	<b>DR603</b>	MATERIAL:		MATERIAL:	
MATERIAL:		MATERIAL:		MATERIAL:	
MATERIAL:		MATERIAL:		MATERIAL:	
MATERIAL:		MATERIAL:		MATERIAL:	

<p>9000 +/- 1300 Dia 9 Min</p>	<p>30 +/- 10 DS 412 OR DS 435 50 +/- 20 Ø 6 +/- 1.5 To fit DS410 To fit in sphere 50 dia</p>	
<p>MATERIAL: <b>Fibre rope- Mainsheet</b> <b>DS380</b></p>	<p>MATERIAL: <b>Stainless steel or plastic composite</b> <b>DS412</b> <b>DS435</b></p>	
<p>1300 +/- 150 DS412 or DS435 To fit DT205 100 +/- 100 Ø 4.5 +/- 1</p>		<p>To fit DM366 To fit DS421</p>
<p>MATERIAL: <b>Fibre rope-Restraining line</b> <b>DS410</b></p>	<p>MATERIAL: <b>Metal</b> <b>DS419</b></p>	
<p>15 Max 100 Max 1.5 +/- 0.75 thick 15 Max To fit DA445 Ø 4 +/- 2</p>	<p>60 +/- 5 1050 +/- 20 60 +/- 5 280 +/- 5 180 +/- 5</p>	
<p>MATERIAL: <b>Optional</b> <b>DS425</b></p>	<p>MATERIAL: <b>Cloth or plastic</b> <b>DS423</b></p>	
<p>Jib bag Mainsail bag</p>		<p>15% of A Min 66% of A Min 15% of A Min A = 250 Min 20% of A Min</p>
<p>MATERIAL: <b>Optional</b> <b>DS430</b> <b>DS431</b></p>	<p>MATERIAL: <b>Cloth or plastic</b> <b>DS424</b></p>	
<p>850 +/- 400 100 +/- 100 Dia 4 +/- 2</p>	<p>600 +/- 200 Dia 4 +/- 2</p>	
<p>MATERIAL: <b>Fibre rope</b> <b>DS432</b></p>	<p>MATERIAL: <b>Fibre rope</b> <b>DS433</b></p>	<p>MATERIAL: <b>Metal</b> <b>DS434</b></p>

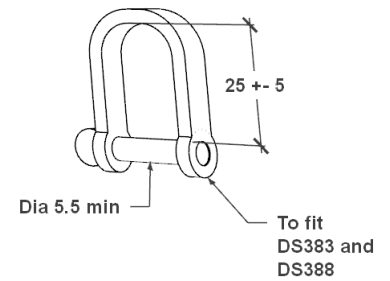
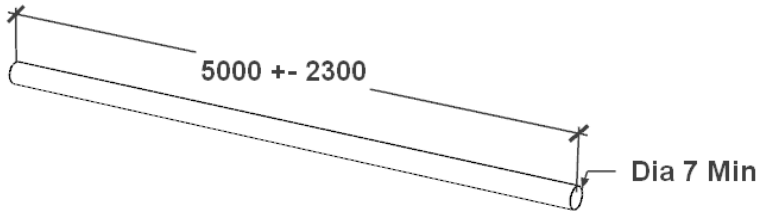

MATERIAL: Fibre rope—Traveller control line

DS381

MATERIAL: Stainless steel

DS382

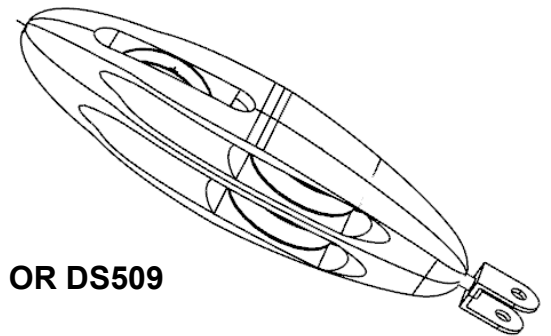
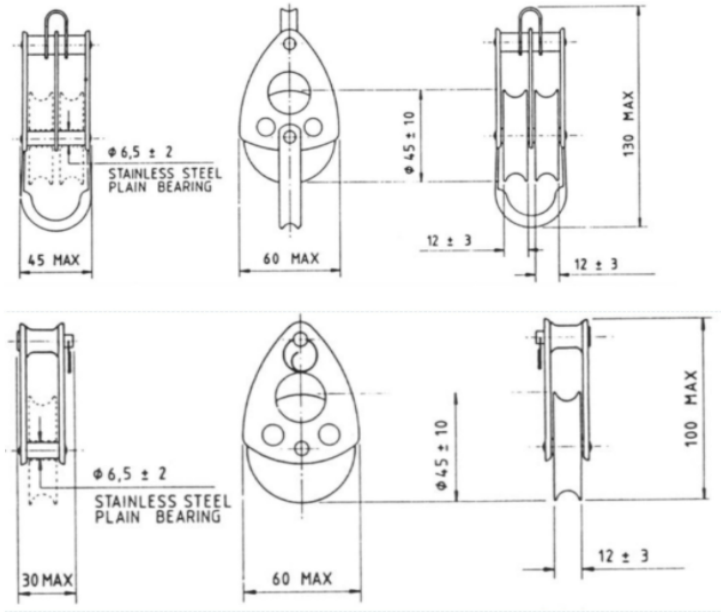

MATERIAL: Plastic, stainless steel, plastic composite

DS383, DS384, DS509

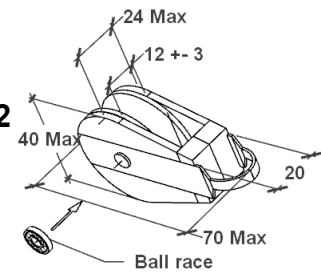
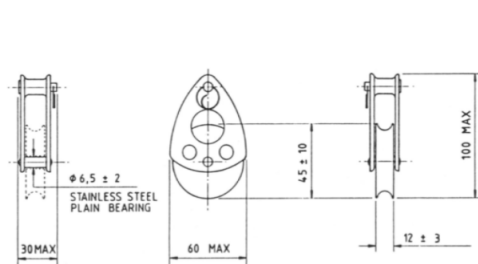

MATERIAL: Plastic, stainless steel, plastic composite

DS402, DS512

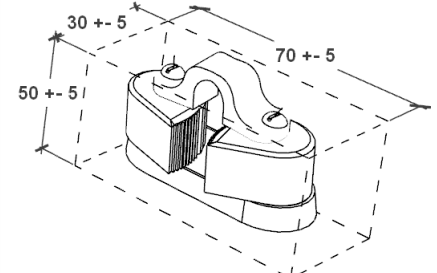
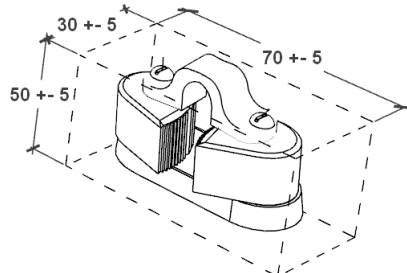

MATERIAL:

MATERIAL: Plastic, stainless steel, plastic composite

DS514

MATERIAL: Plastic, stainless steel, plastic composite

DS515

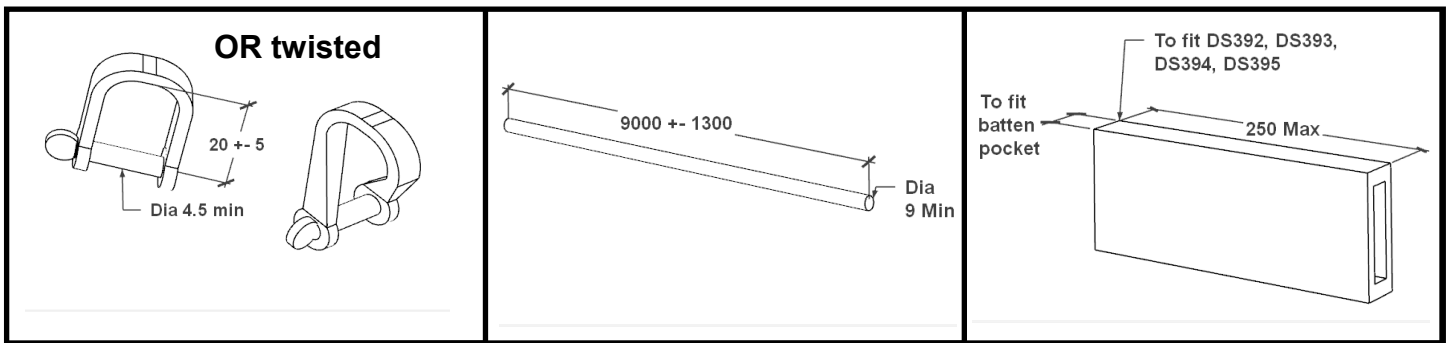

<b>MATERIAL:</b> Stainless steel	<b>DS390</b>	<b>MATERIAL:</b> Fibre rope-Jib sheet	<b>DS400</b>	<b>MATERIAL:</b> Soft plastic, rubber, solid or foam tape	<b>DS405</b>
-------------------------------------	--------------	--	--------------	--	--------------

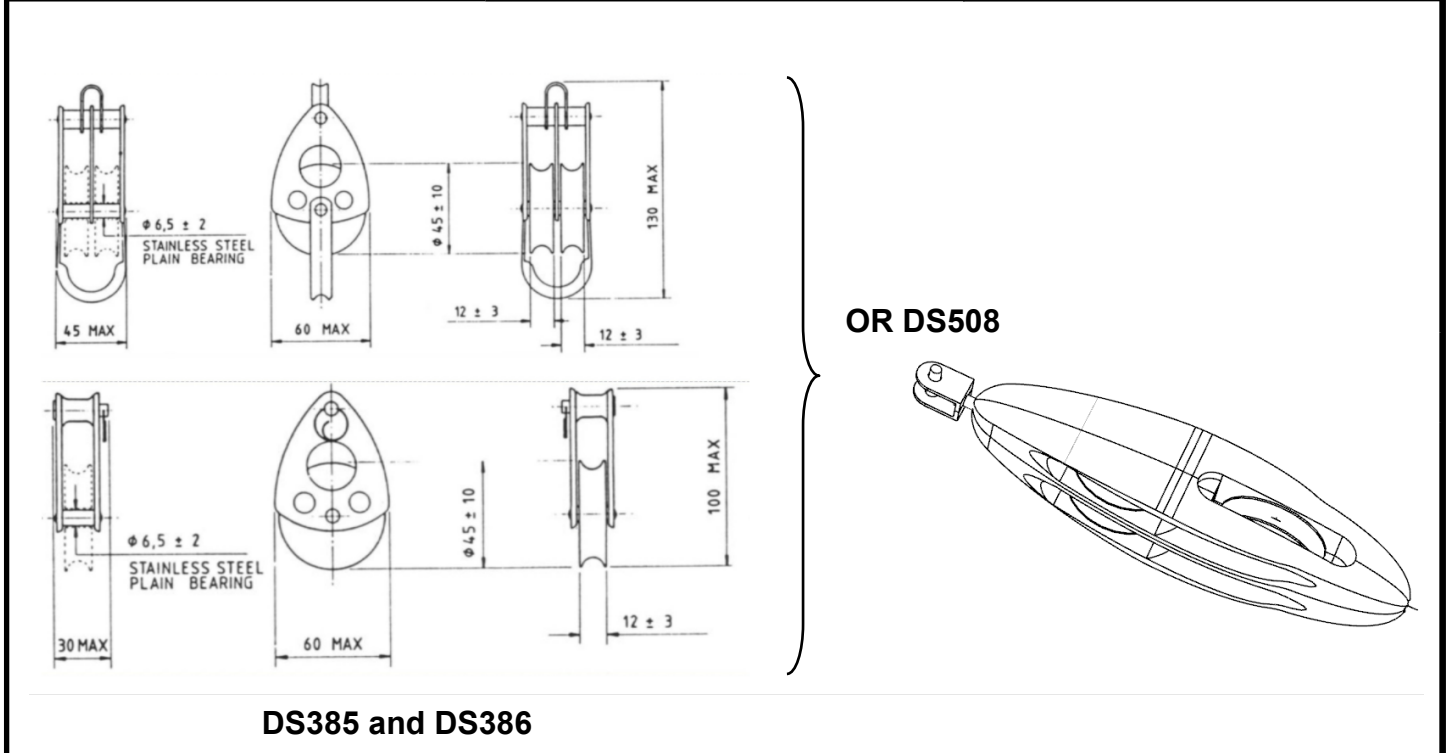

<b>MATERIAL:</b> Plastic, stainless steel, plastic composite	<b>DS385, DS386, DS508</b>
---	----------------------------

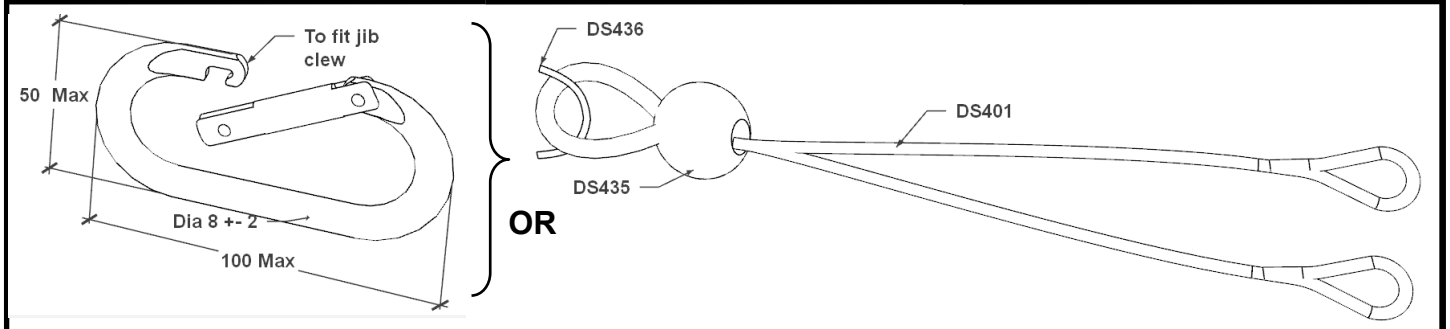

<b>MATERIAL:</b> Stainless steel	<b>DS404</b>	<b>Jib stop assembly—DS436 and DS435 Replaces DW323 or DS404</b>
-------------------------------------	--------------	--

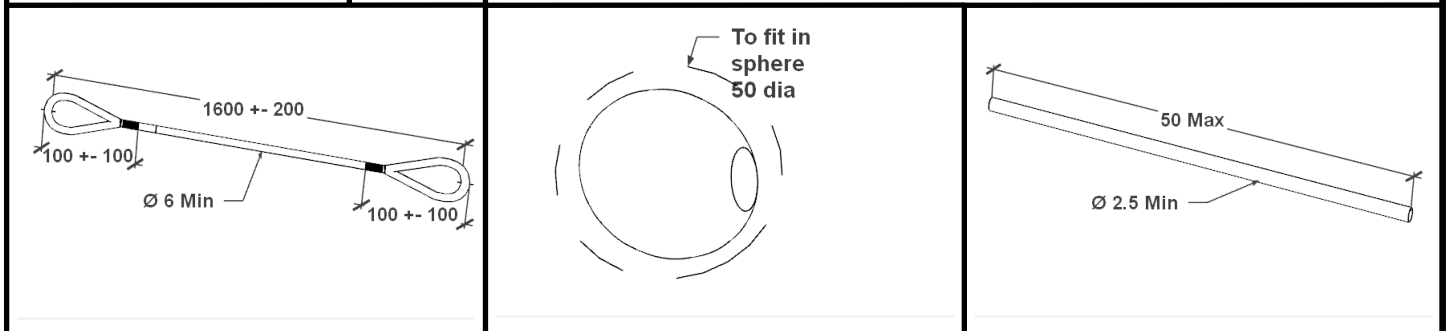

<b>MATERIAL:</b> Fibre rope-Jib stop	<b>DS401</b>	<b>MATERIAL:</b> Plastic composite	<b>DS435</b>	<b>MATERIAL:</b> Fibre rope-Jib stop lock	<b>DS436</b>
---	--------------	---------------------------------------	--------------	--	--------------

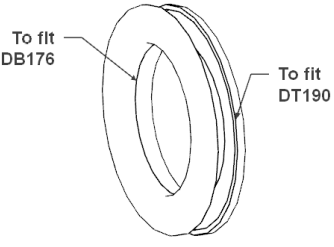
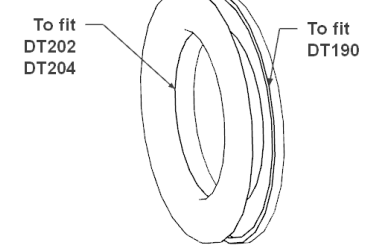
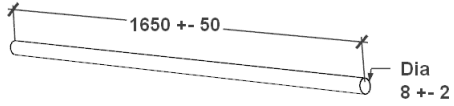
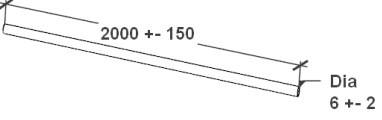
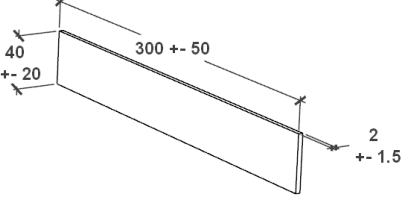
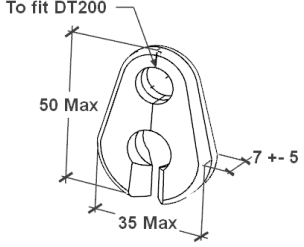
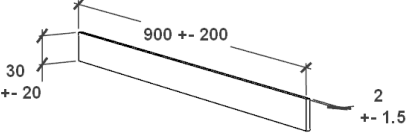
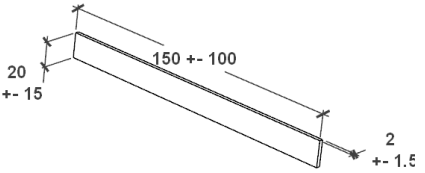
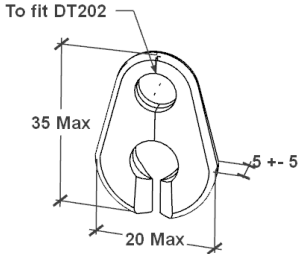
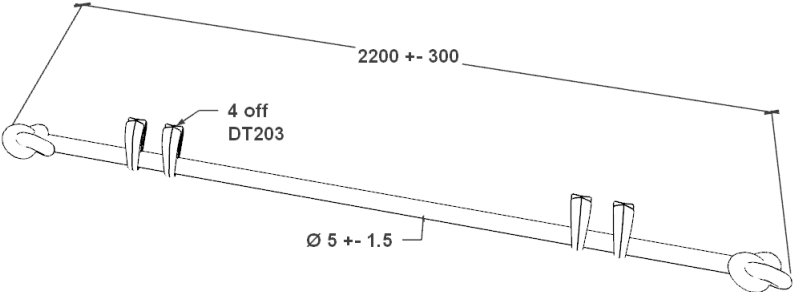
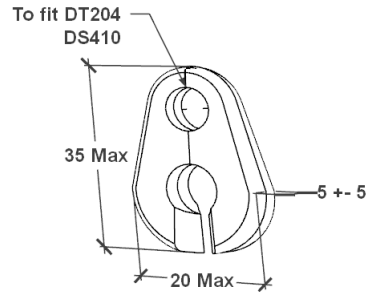
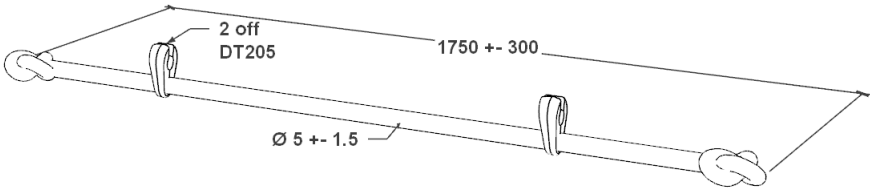
						
<b>MATERIAL:</b> <b>Metal, plastic, plastic composite</b>	<b>DT192</b>	<b>MATERIAL:</b> <b>Metal, plastic, plastic composite</b>	<b>DT193</b>	<b>MATERIAL:</b> <b>Fibre rope</b>	<b>DT194</b>	
						
<b>MATERIAL:</b> <b>Fibre rope</b>	<b>DT195</b>	<b>MATERIAL:</b> <b>Flexible material</b>	<b>DT196</b>	<b>MATERIAL:</b> <b>Optional</b>	<b>DT199</b>	
						
<b>MATERIAL:</b> <b>Flexible material</b>	<b>DT198</b>	<b>MATERIAL:</b> <b>Flexible material</b>	<b>DT200</b>	<b>MATERIAL:</b> <b>Optional</b>	<b>DT203</b>	
						
<b>MATERIAL:</b> <b>Elastic fibre</b>			<b>DT202</b>	<b>MATERIAL:</b> <b>Optional</b>		<b>DT205</b>
						
<b>MATERIAL:</b> <b>Elastic fibre</b>			<b>DT204</b>	<b>MATERIAL:</b>		

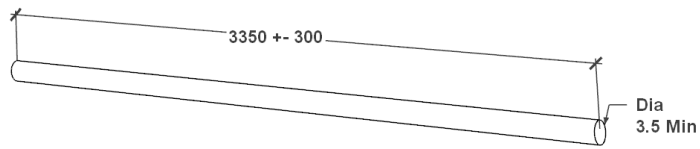

MATERIAL:

Fibre rope-Trampoline lashing

DT206

MATERIAL:

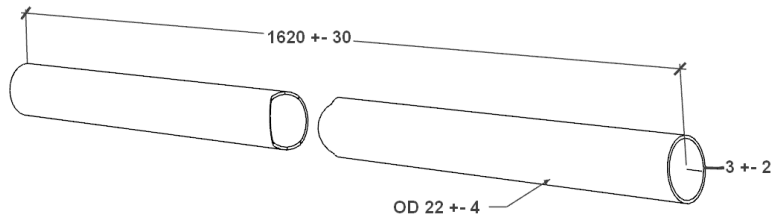

MATERIAL:

Plastic, aluminium alloy

DT207

MATERIAL:

MATERIAL:

MATERIAL:

MATERIAL:

MATERIAL:

MATERIAL:



MATERIAL:

MATERIAL:

MATERIAL:

MATERIAL:

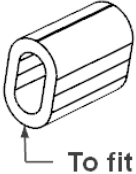
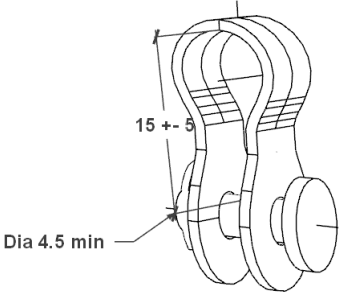
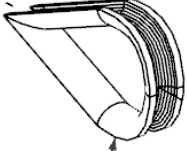
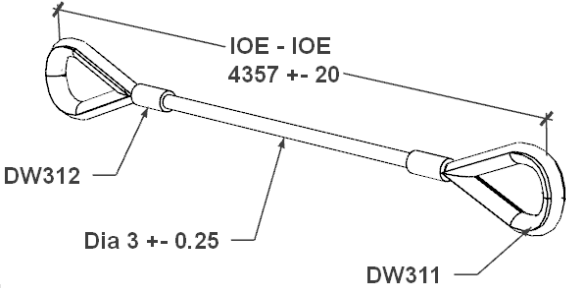
<p><b>MATERIAL:</b> Stainless steel wire, multistrand</p>	<p><b>DW280</b></p>	<p><b>MATERIAL:</b> Optional</p>	<p><b>DW282</b></p>
<p><b>MATERIAL:</b> Optional</p>	<p><b>DW281</b></p>	<p><b>MATERIAL:</b> Copper Copper alloy</p>	<p><b>DW283</b></p>
<p><b>MATERIAL:</b> Optional</p>	<p><b>DW284</b></p>	<p><b>MATERIAL:</b> Stainless steel</p>	<p><b>DW289</b></p>
<p><b>MATERIAL:</b> Fibre rope-Trapeze adjusting</p>	<p><b>DW285</b></p>	<p><b>MATERIAL:</b> Stainless steel wire, multistrand</p>	<p><b>DW300</b></p>
<p><b>MATERIAL:</b> Stainless—No moving parts</p>	<p><b>DW288</b></p>	<p><b>MATERIAL:</b> Stainless steel</p>	<p><b>DW301</b></p>

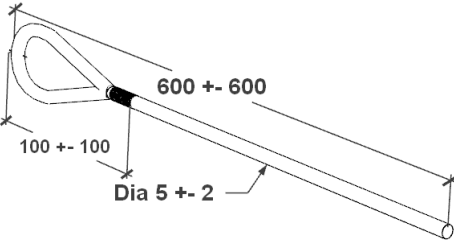
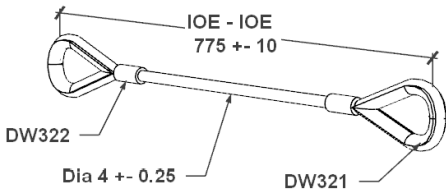
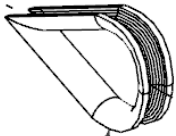
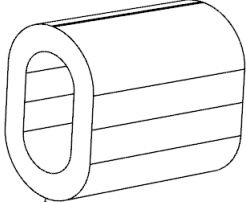
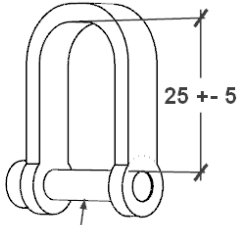
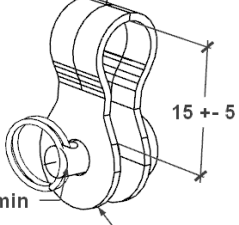
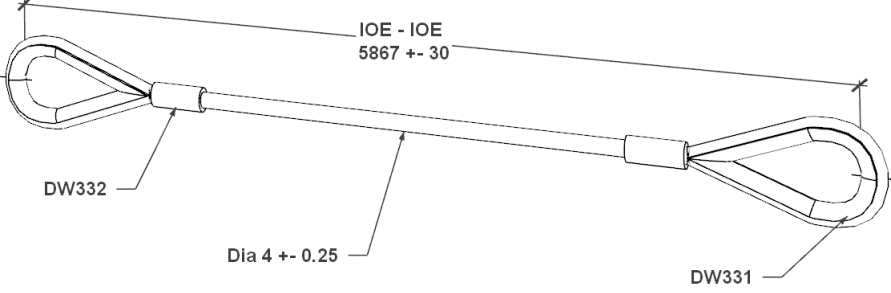
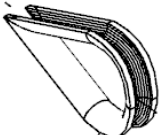
 <p>To fit DW300</p>	 <p>15 +/- 5 Dia 4.5 min</p>	 <p>To fit DW310</p>					
<p>MATERIAL: <b>Copper Copper alloy</b></p>	<p><b>DW302</b></p>	<p>MATERIAL: <b>Stainless steel</b></p>	<p><b>DW303</b></p>	<p>MA- <b>Stainless steel</b></p>	<p><b>DW311</b></p>		
 <p>IOE - IOE 4357 +/- 20 DW312 Dia 3 +/- 0.25 DW311</p>			 <p>To fit DW310</p>				
<p>MATERIAL: <b>Stainless steel wire, multistrand</b></p>			<p><b>DW310</b></p>	<p>MATERIAL: <b>Copper Copper alloy</b></p>		<p><b>DW312</b></p>	
 <p>600 +/- 600 100 +/- 100 Dia 5 +/- 2</p>	 <p>IOE - IOE 775 +/- 10 DW322 Dia 4 +/- 0.25 DW321</p>		 <p>To fit DW320 DW323 DW324 DW325</p>				
<p>MATERIAL: <b>Fibre rope</b></p>	<p><b>DW313</b></p>	<p>MATE- <b>Stainless steel wire, multistrand</b></p>		<p><b>DW320</b></p>	<p>MATERIAL: <b>Stainless steel</b></p>		<p><b>DW321</b></p>
 <p>To fit DW320</p>	 <p>25 +/- 5 Dia 5.5 min</p>		 <p>15 +/- 5 Dia 4.5 min To fit DW311 DW321</p>				
<p>MATERIAL: <b>Copper Copper alloy</b></p>	<p><b>DW322</b></p>	<p>MATERIAL: <b>Stainless steel</b></p>		<p><b>DW323</b></p>	<p>MATERIAL: <b>Stainless steel</b></p>		<p><b>DW324</b></p>
 <p>IOE - IOE 5867 +/- 30 DW332 Dia 4 +/- 0.25 DW331</p>			 <p>To fit DW330 DW333 DW334</p>				
<p>MATERIAL: <b>Stainless steel wire, multistrand</b></p>			<p><b>DW330</b></p>	<p>MATERI- <b>Stainless steel</b></p>		<p><b>DW331</b></p>	

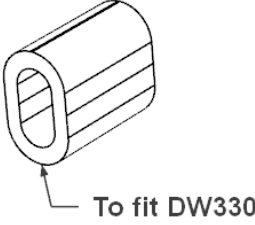
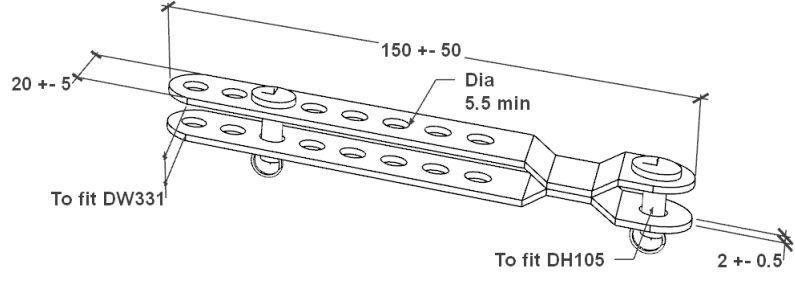
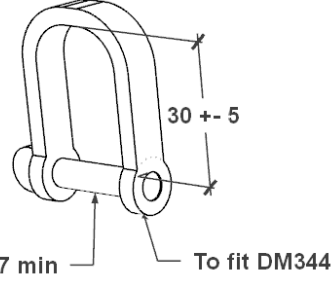
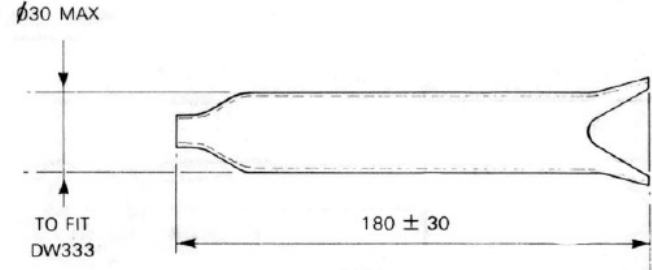

			
<b>MATERIAL: Copper</b> <b>Copper alloy</b>		<b>MATERIAL: Stainless steel</b>	
<b>DW332</b>		<b>DW333</b>	
			
<b>MATERIAL: Stainless steel</b>		<b>MATERIAL: Optional</b>	
<b>DW334</b>		<b>DW329</b>	
<b>MATERIAL:</b>		<b>MATERIAL:</b>	
<b>MATERIAL:</b>		<b>MATERIAL:</b>	
<b>MATERIAL:</b>		<b>MATERIAL:</b>	
<b>MATERIAL:</b>		<b>MATERIAL:</b>	



# DART18 ASSEMBLY OF PARTS AND THEIR IDENTITIES

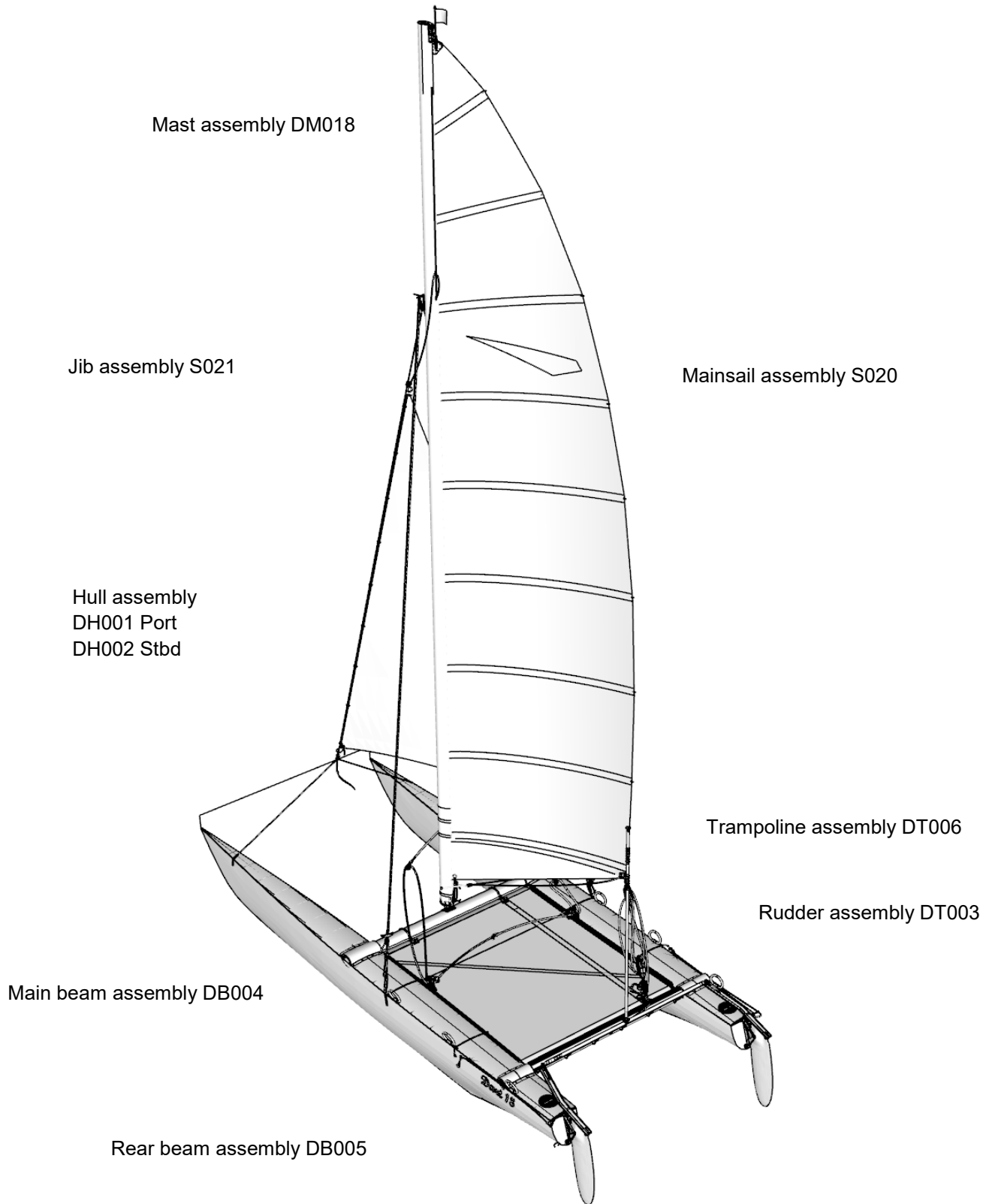

# DART18 ASSEMBLY OF PARTS AND THEIR IDENTITIES

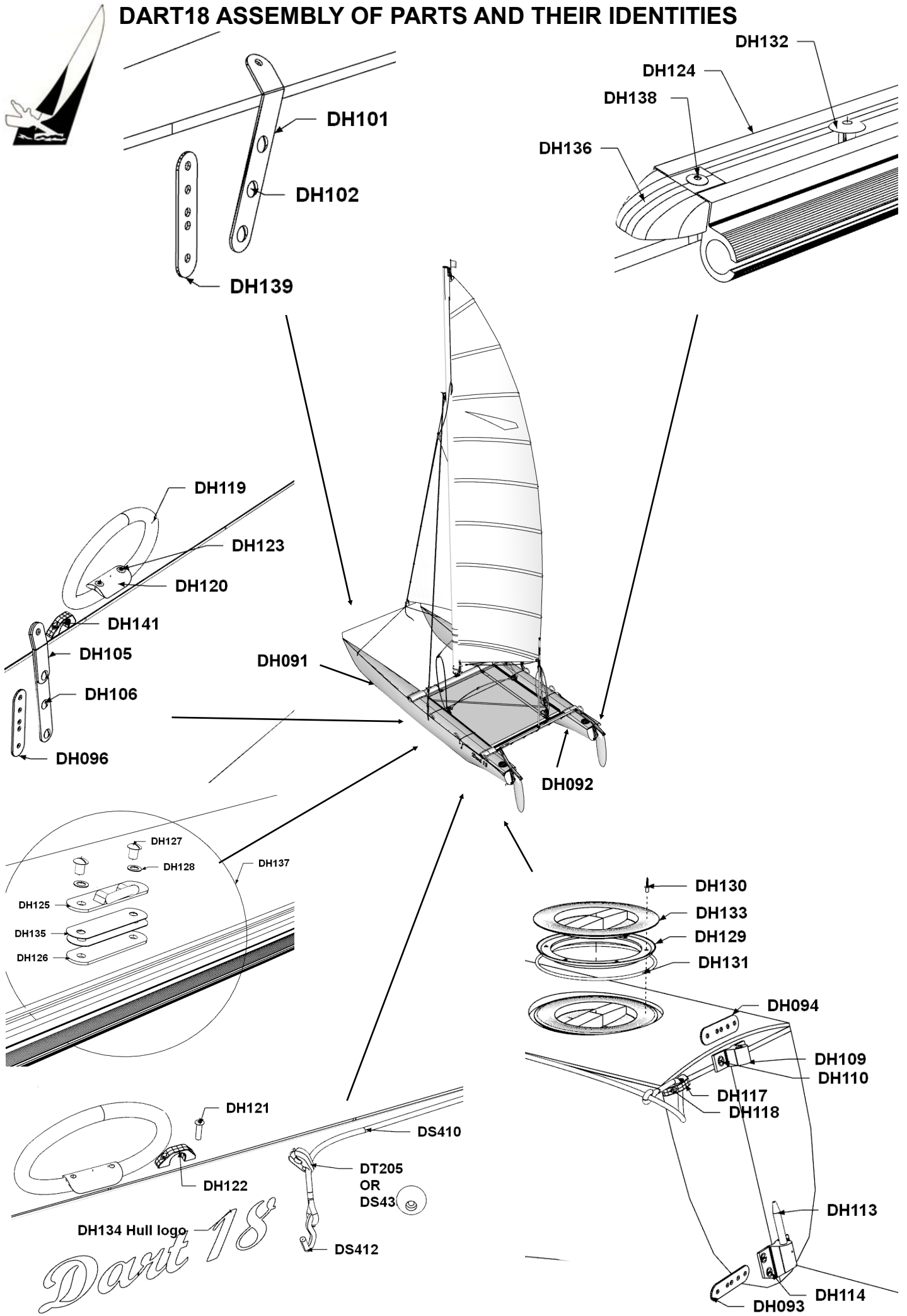

DH134 Hull logo  
*Dart 18*

# DART18 ASSEMBLY OF PARTS AND THEIR IDENTITIES

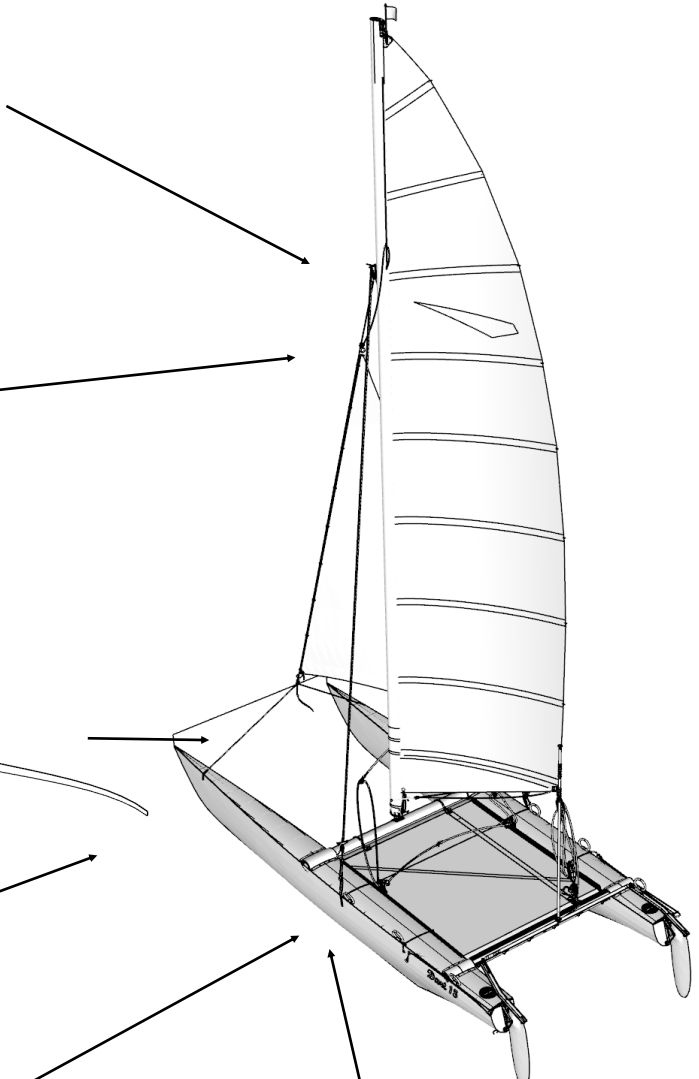
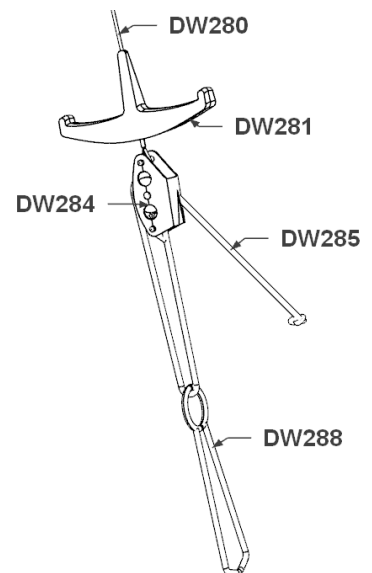
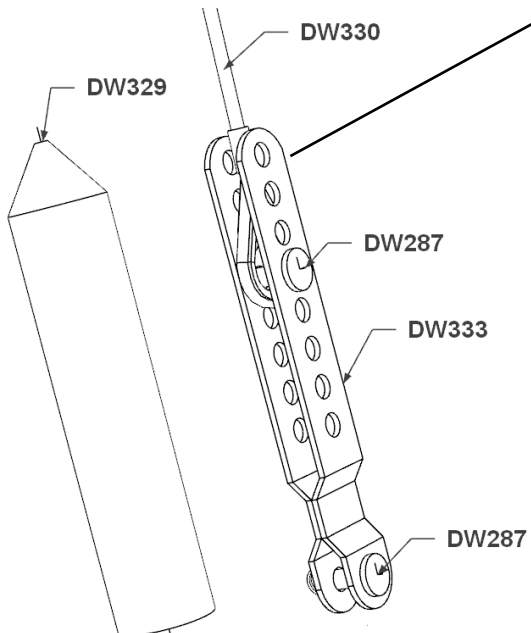
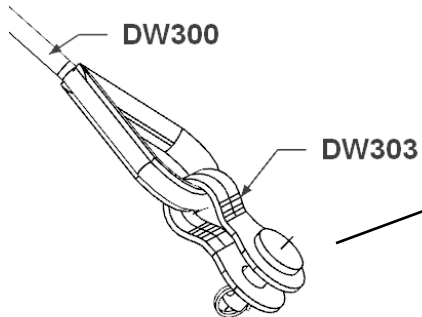
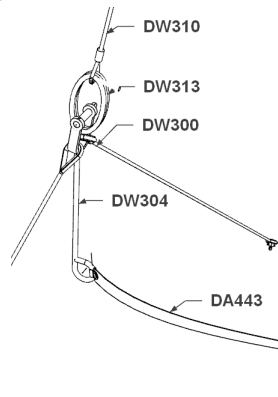
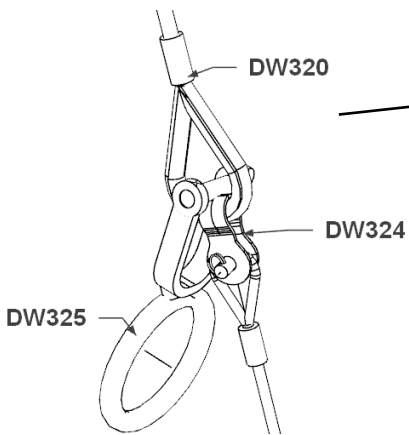
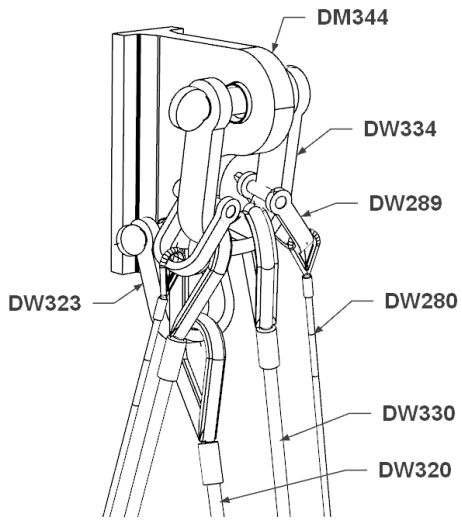



# DART18 ASSEMBLY OF PARTS AND THEIR IDENTITIES

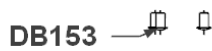
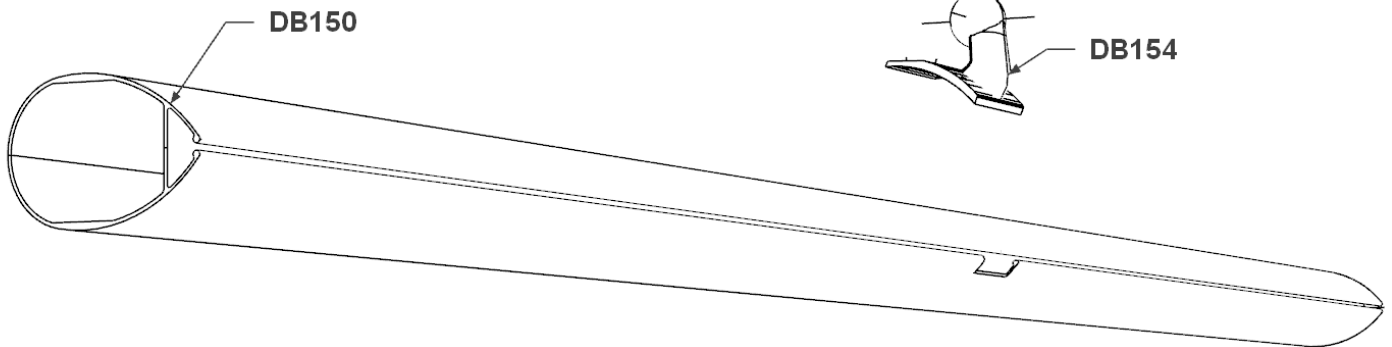
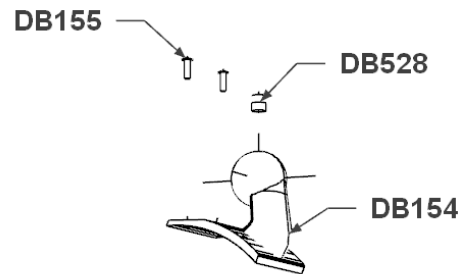
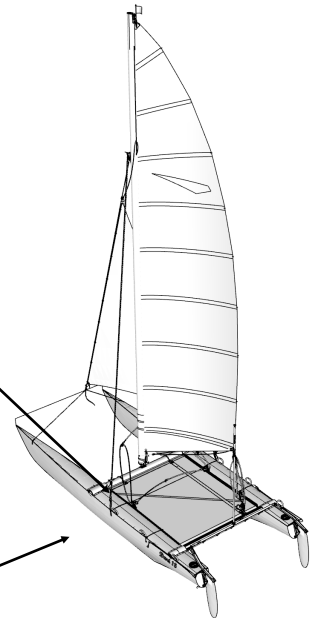
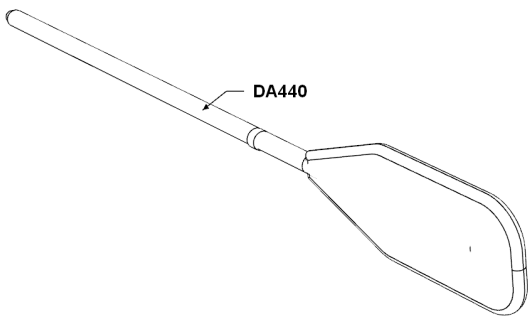
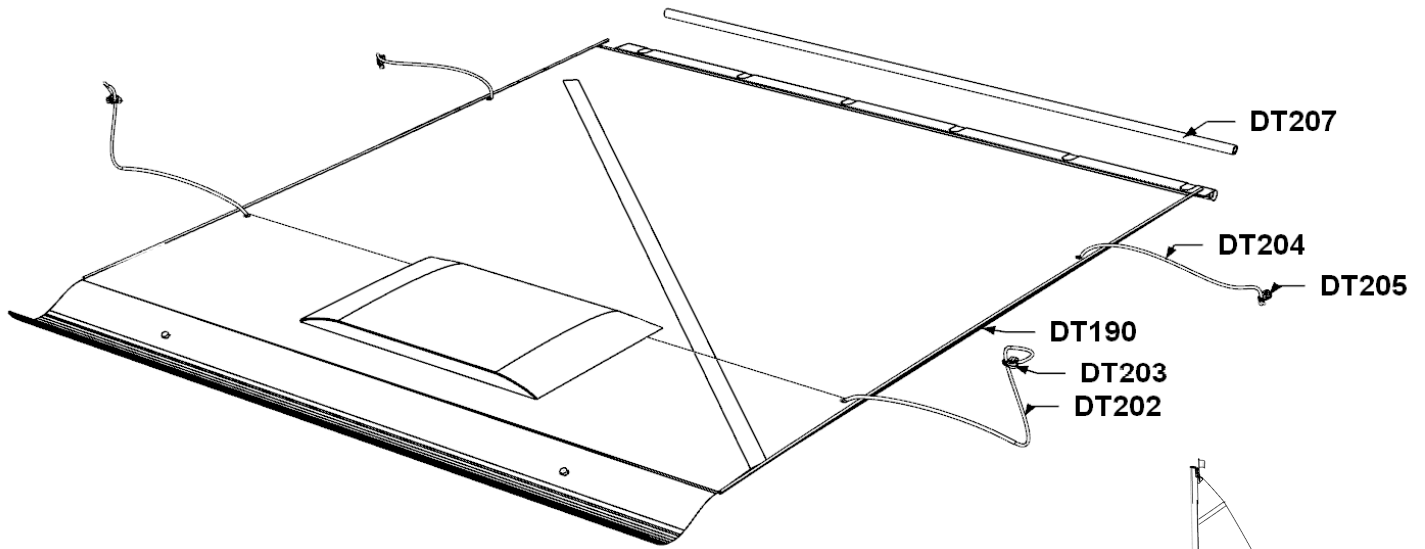



# DART18 ASSEMBLY OF PARTS AND THEIR IDENTITIES

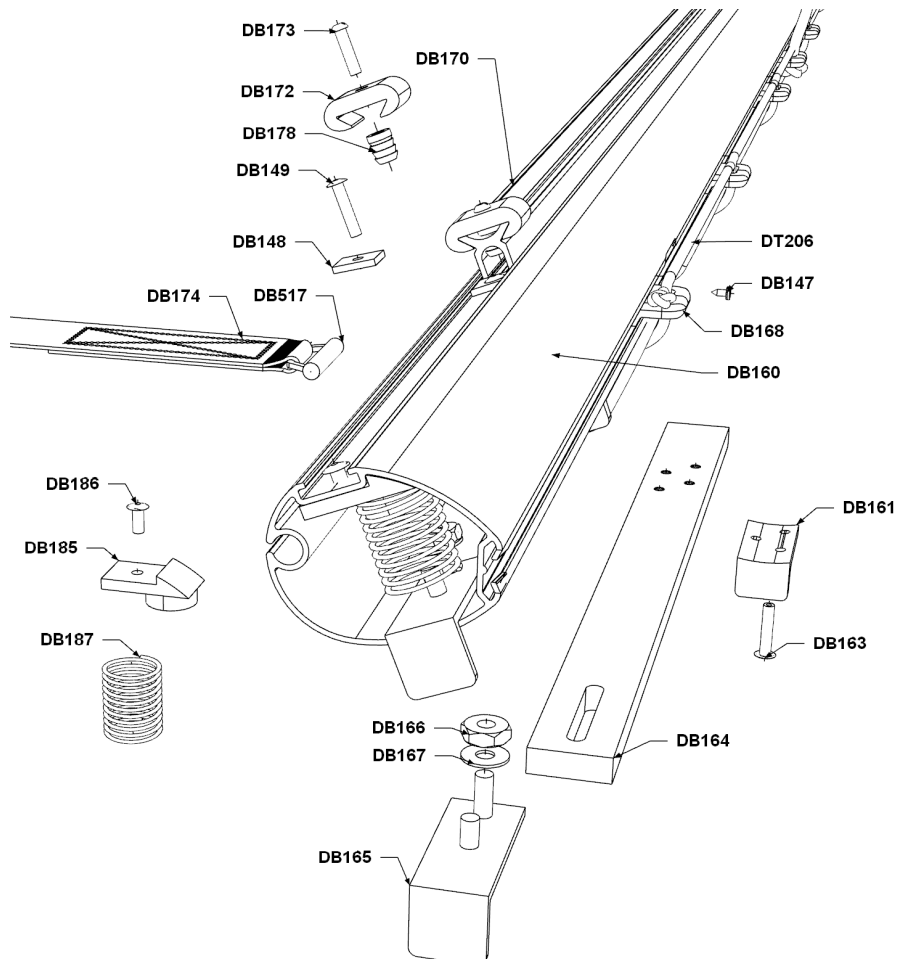
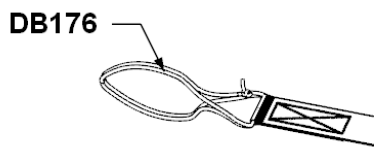
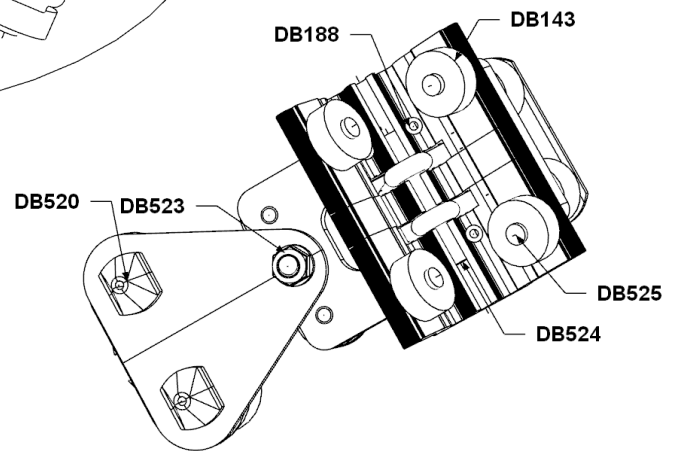
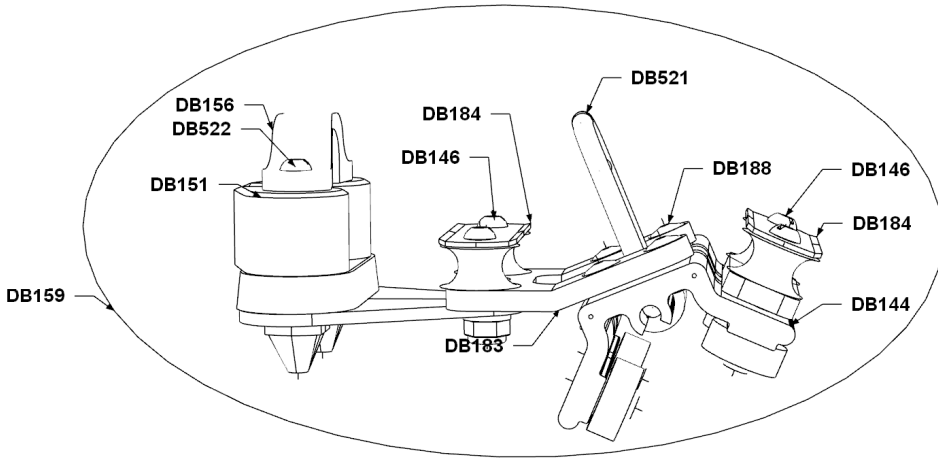
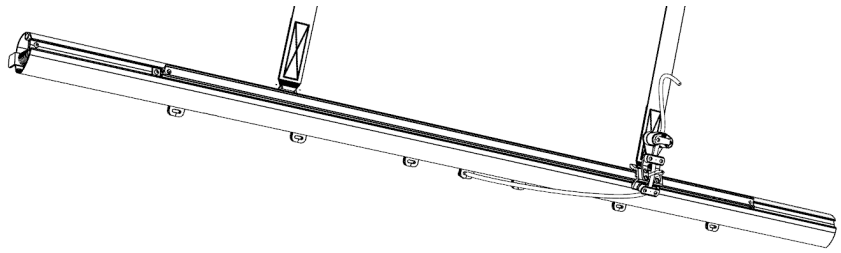

# DART18 ASSEMBLY OF PARTS AND THEIR IDENTITIES

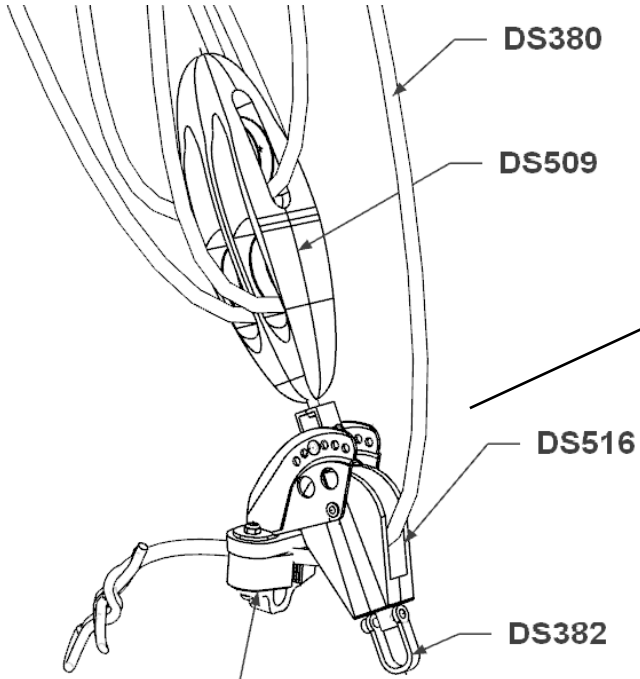
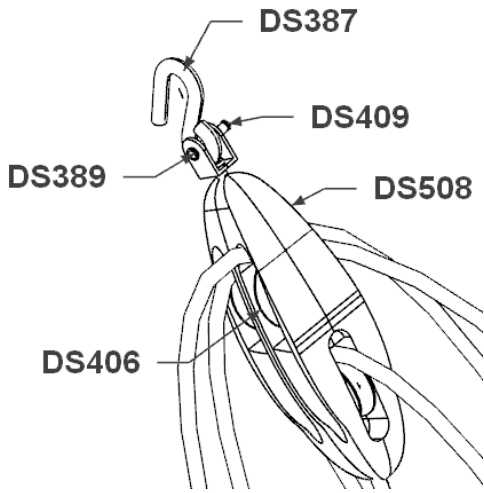

DS515 OR DS510

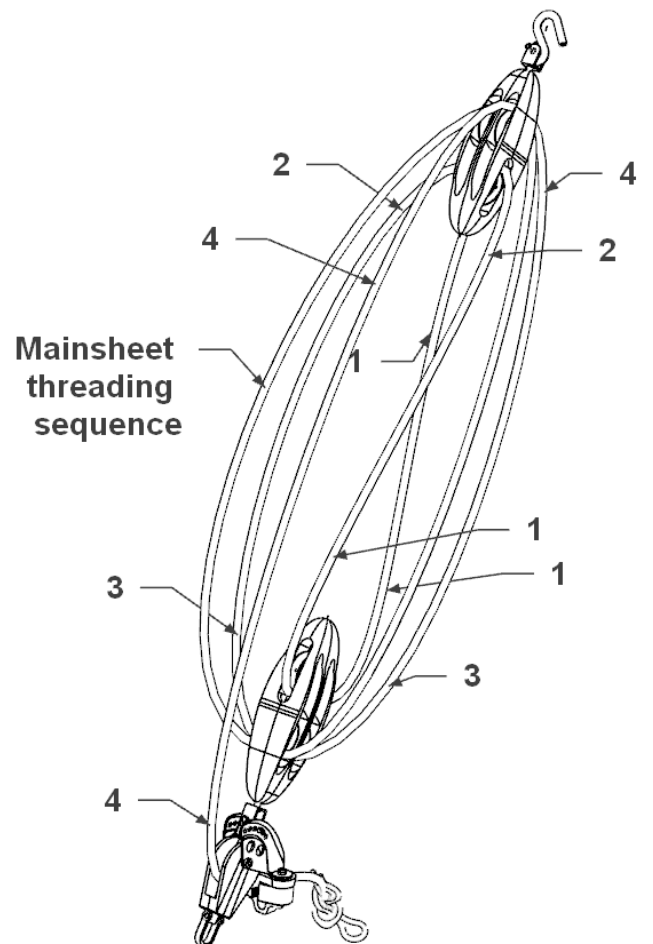
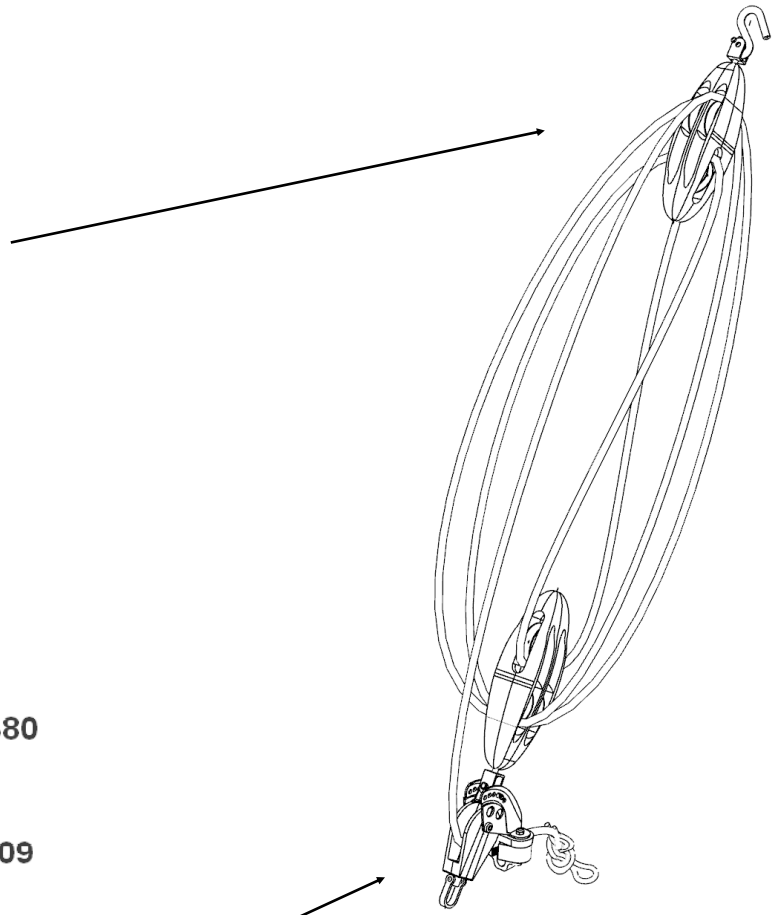
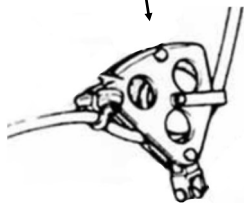



# DART18 ASSEMBLY OF PARTS AND THEIR IDENTITIES

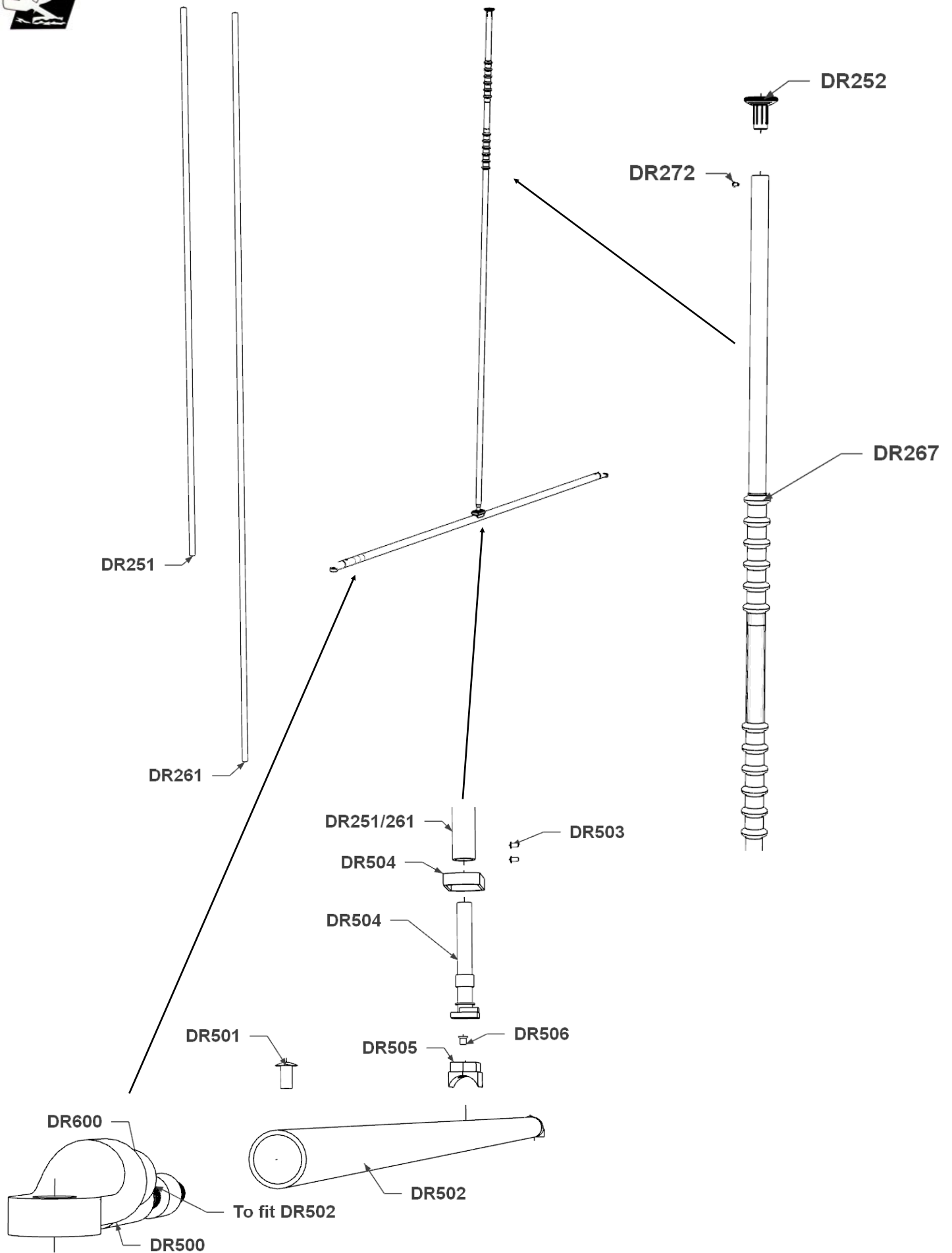



# DART18 ASSEMBLY OF PARTS AND THEIR IDENTITIES

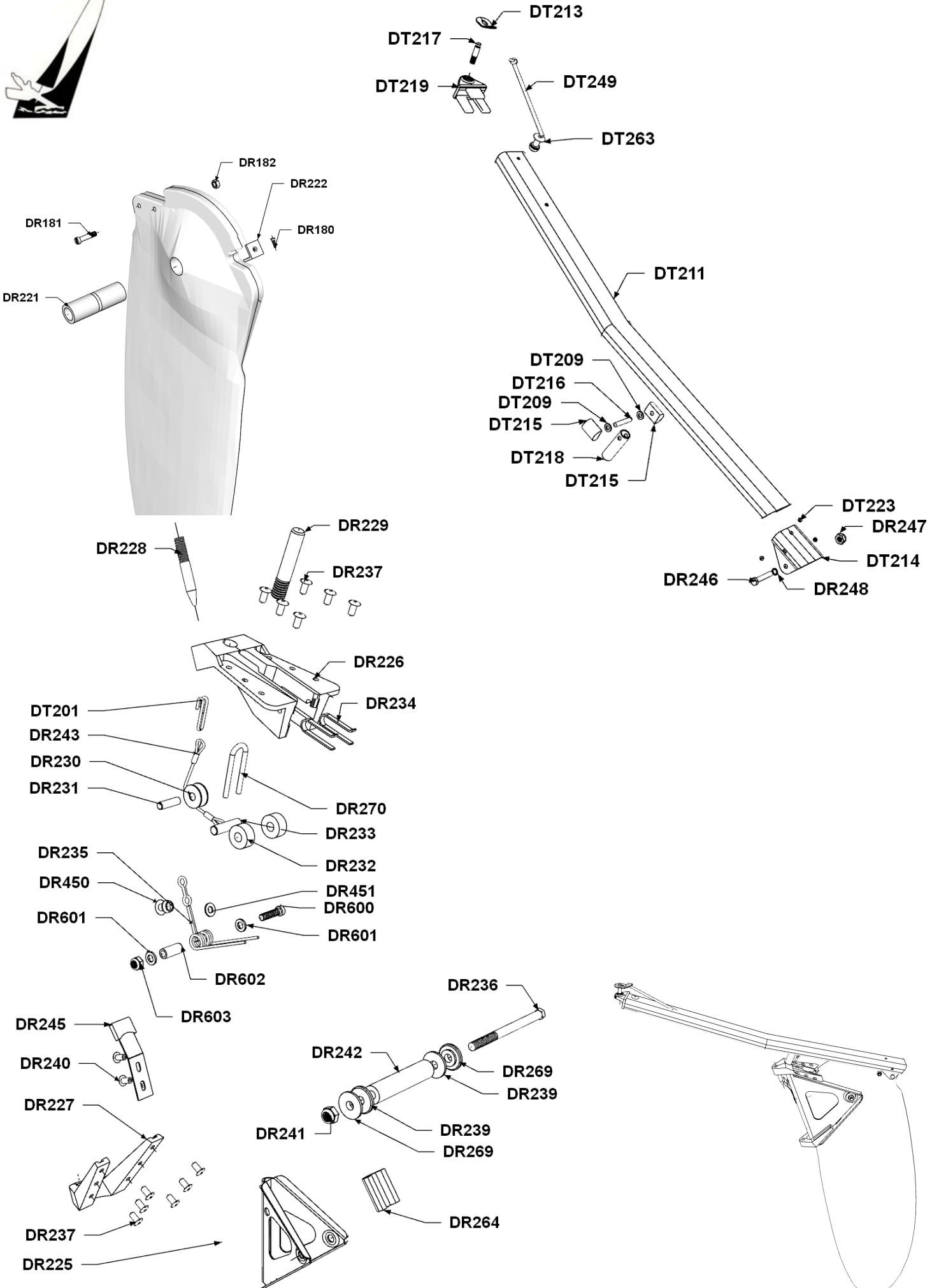

# DART18 ASSEMBLY OF PARTS AND THEIR IDENTITIES

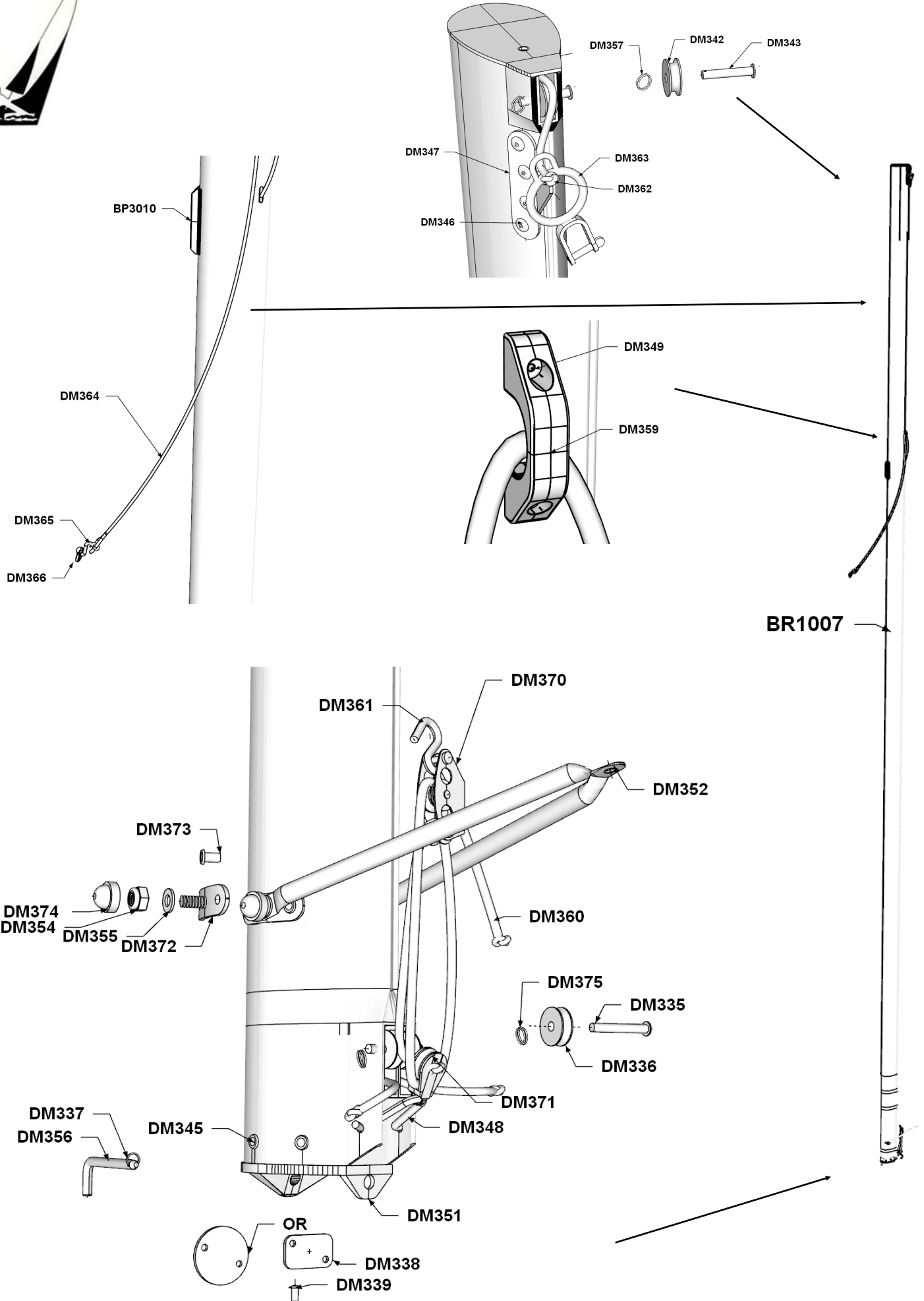



# DART18 ASSEMBLY OF PARTS AND THEIR IDENTITIES

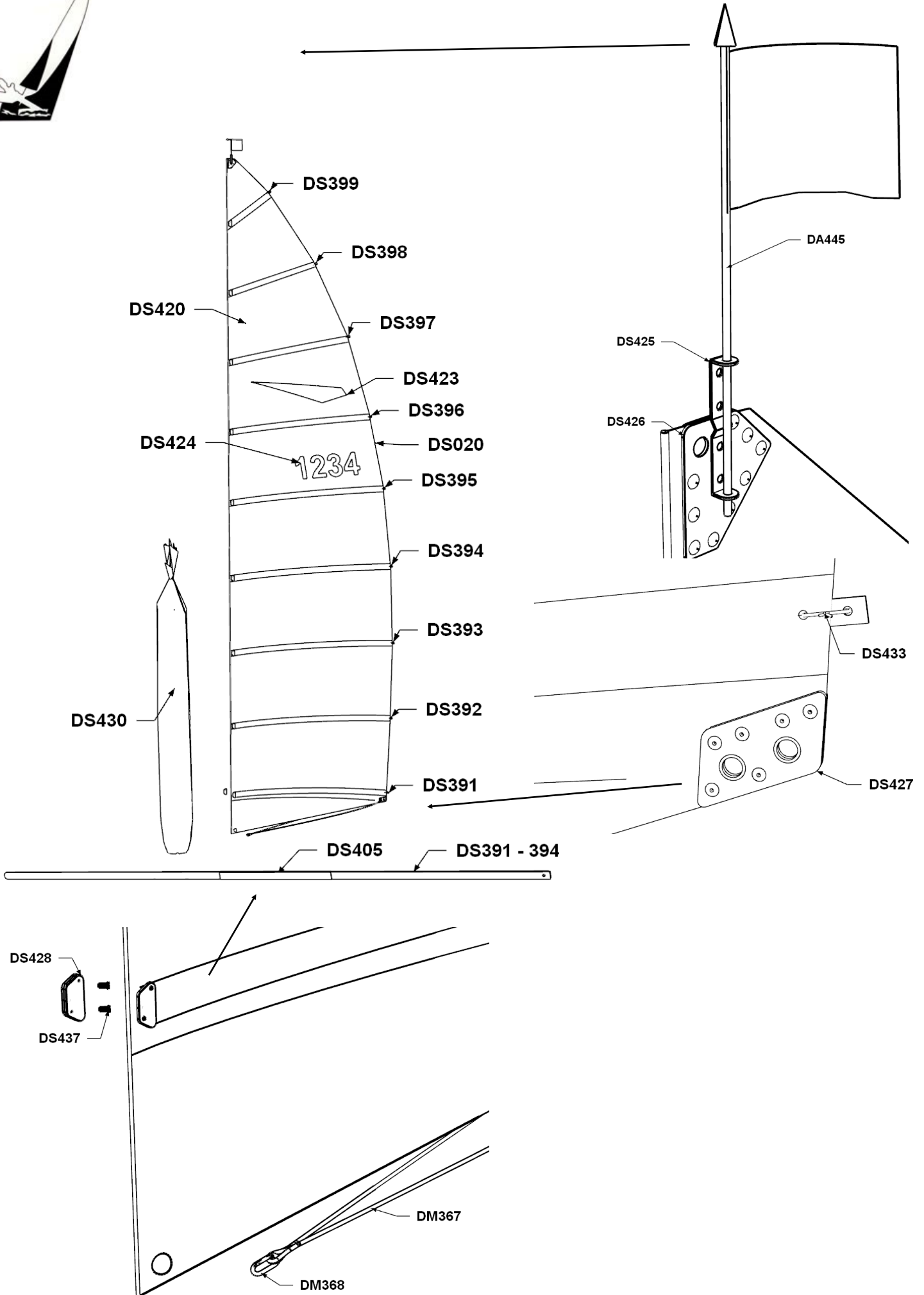

# DART18 ASSEMBLY OF PARTS AND THEIR IDENTITIES

